

(1) [NAME OF POWER PURCHASER]

- and -

(2) [NAME OF POWER SUPPLIER]

POWER PURCHASE AGREEMENT

relating to
the Geothermal Power Generation Plant
at [LOCATION]

IMPORTANT: READ BEFORE USING THIS DRAFT AGREEMENT

This draft power purchase agreement ("Agreement") has been prepared as part of the Government of Tanzania's PPP Capacity Building Project ("Project") and should be read in conjunction with the Power Public Private Partnership Toolkit ("Toolkit") published under the Project.

This Agreement is to be used as a starting point in the procurement of a geothermal power station. Although many provisions and the general structure of this Agreement may apply to power stations with other fuel sources, this Agreement is not directly suitable for use in respect of other means of power generation.

Use of the "□" symbol in this Agreement indicates terms that will need to be decided on a case-by-case basis.

The Agreement envisages the Plant being either Open Cycle and/or Combined Cycle and, as a result of being Combined Cycle, it may be built and operated in two phases.

The Toolkit anticipates that a power purchase agreement will be included in the Request for Proposal issued as part of a competitive tendering process. Before being released as part of a Request for Proposal, this Agreement must be reviewed and any gaps completed and the comment boxes (including this one) must be deleted. The Toolkit includes a User Guide that explains the use of this Agreement and possible negotiation positions. The User Guide must not be circulated outside of []. Legal advice must be sought before any substantive amendments are made to this Agreement.

This Agreement is for use by [INSERT RELEVANT DEPARTMENT/AUTHORITY] only and may not be used by any other party without the prior written consent of [].

TABLE OF CONTENTS

1.	DEFINITIONS AND INTERPRETATION	2
2.	TERM	15
3.	CONDITIONS PRECEDENT	16
4.	PRE-OPERATION PERIOD.....	17
5.	GENERAL COVENANTS OF THE SELLER IN RESPECT OF THE PLANT	24
6.	CONSTRUCTION OF THE COMPLEX.....	24
7.	INTERCONNECTION.....	30
8.	METERING AND TELECOMMUNICATIONS	33
9.	OPERATION AND MAINTENANCE OF THE PLANT	36
10.	TESTING AND CAPACITY RATINGS	45
11.	SALE AND PURCHASE OF ENERGY AND CAPACITY	47
12.	COMPENSATION, PAYMENT AND BILLING	47
13.	INSURANCE.....	54
14.	REPRESENTATIONS AND WARRANTIES OF THE PURCHASER	55
15.	REPRESENTATIONS AND WARRANTIES OF THE SELLER	56
16.	INDEMNIFICATION AND LIABILITY	57
17.	CHANGE IN LAW.....	60
18.	FORCE MAJEURE	61
19.	TAXES.....	64
20.	DEFAULTS AND TERMINATION.....	65
21.	RESOLUTION OF DISPUTES.....	75
22.	ASSIGNMENT	80
23.	NOTICES.....	81
24.	MISCELLANEOUS	82
	SCHEDULE 1 - PROJECT-SPECIFIC TERMS, MINIMUM FUNCTIONAL, AND FUEL SPECIFICATIONS.....	87
	Part 1: Project-specific definitions:.....	88
	Part 2: Plant Characteristics	89
	Part 3: Transmission Specifications.....	90
	SCHEDULE 2 - INTERCONNECTION FACILITIES	97
	SCHEDULE 3 - TESTING AND COMMISSIONING	98
	SCHEDULE 4 - METERING AND TELECOMMUNICATIONS	102
	SCHEDULE 5 - PAYMENTS [, INDEXATION AND ADJUSTMENT - IF APPLICABLE]104	

SCHEDULE 6 - LIST OF INDEPENDENT ENGINEERS.....	116
PARTIES MAY WISH TO PRE-AGREE A SHORTLIST OF CANDIDATES FOR THE ROLE OF INDEPENDENT ENGINEER, IN ACCORDANCE WITH THE TANZANIAN LAWS GOVERNING INSTITUTIONS THAT ARE LEGALLY COMPONENT AND AUTHORIZED TO PROVIDE ENGINEERS TO CARRY OUT ARBITER ISSUES.	116
SCHEDULE 7 - CONSTRUCTION REPORTS.....	117
SCHEDULE 8 - SECURITY PACKAGE.....	118
SCHEDULE 9 - CONDITIONS PRECEDENT.....	119
SCHEDULE 10 - NAMES OF INITIAL SHAREHOLDERS.....	120
SCHEDULE 11 - TERMINATION AMOUNTS.....	121
Part 1: Calculation of Transfer Values.....	121
1. Applicable Transfer Values.....	121
2. Calculation of Transfer Value.....	121
Part 2: Termination Payments.....	125
Part 3: Post Completion Adjustments.....	125
SCHEDULE 12 - INSURANCE.....	127

THIS POWER PURCHASE AGREEMENT (hereinafter referred to as the "Agreement") is made on..... day.....20..... at [LOCATION]

BETWEEN:

- (1) [NAME OF POWER PURCHASING ENTITY],[BRIEFLY DESCRIBE PURCHASER'S LEGAL STATUS], having its registered office at [ADDRESS] ("**Purchaser**"); and
- (2) [NAME OF POWER SUPPLIER], a Company duly incorporated under the Laws of [COUNTRY OF INCORPORATION] of P.O. Box [insert address], having its registered office located at [Location] ("**Seller**").

Both the Purchaser and the Seller are herein referred to individually as a "**Party**" and collectively as the "**Parties**".

RECITALS

WHEREAS:

- A the Seller and the Purchaser are companies duly incorporated and validly existing under the laws of Tanzania, each possesses all requisite corporate and legal authority to execute this Agreement, and each is permitted by applicable laws and regulations to sell or purchase power as appropriate;
- B the Seller has proposed to the Purchaser that the Seller will design, engineer, construct, insure, Commission (as hereinafter defined), operate and maintain an approximately [] MW (gross) Solar powered electric generation facility (the "Complex" (as hereinafter defined)) to be located at the Site (as hereinafter defined) at _____ and with a Contract Capacity (as hereinafter defined) of [] MW (gross) on build, own, operate and transfer basis;
- C the Seller and the Purchaser agree to develop the Project under [an Independent Power Producer (IPP)/Public-Private Partnership (PPP)] arrangements and recognize that training citizens of Tanzania in the design, construction, installation, operation, maintenance and management of the Project and maximizing technology transfer is central to the interests of the Purchaser in the Project; and
- D the Seller wishes to sell and deliver, and the Purchaser wishes to purchase and accept delivery of, the offered capacity and/or associated electric energy to be produced by the Seller from the Plant described in Schedule 1 -, subject to the terms and conditions as set forth in this Agreement.

In consideration of the mutual benefits to be derived and the representations and warranties, conditions, and promises herein contained, and intending to be legally bound hereby, the Seller and the Purchaser hereby agree as follows:

1. DEFINITIONS AND INTERPRETATION

1.1 Definitions

Whenever the following terms appear in this Agreement or the Schedules hereto, whether in the singular or the plural, present, future or past tense, they shall have the meanings stated below unless the context otherwise requires:

"Abandonment" means either (a) the cessation of substantially all activities relating to the construction or operation and maintenance of the Plant, as appropriate (except a cessation that is the direct result of a local strike which occurred and continued despite the reasonable actions or inactions of the Seller or its Contractors); (b) the physical absence of substantially all employees of the Seller and its Contractors from the Site after the commencement of excavation for the foundations of the Plant, in either case (a) or (b) for at least thirty (30) consecutive Days; (c) a persistent failure of the Seller to perform its obligations hereunder such as to suggest an intention to repudiate this Agreement; or (d) a failure by the Seller to resume and continue the performance of substantially all of its obligations under this Agreement within a reasonable period following the cessation of an event of Force Majeure which causes the Party's failure or delay in complying with its obligations under the Agreement.

"Active Power" means the useful component of the product of voltage and current, which the Plant shall provide to or absorb from the Purchaser Grid System and which is measured in Megawatt (MW).

"Affected Party" has the meaning ascribed thereto in Clause 18.1.

"Agreement" means this Power Purchase Agreement, including all schedules thereto, as amended or supplemented from time to time.

"Agreed Rate of Return" shall mean a []% return on equity for the Shareholders.

"Amended Project Document" means any documents supplementing or otherwise amending Original Project Documents, referred to in Clause 4.3.

"Ancillary Services" means such services provided by the Seller relating to electric power production and operation of the Purchaser Grid System other than the provision of electric energy and capacity, including, but not limited to reactive power, voltage control, frequency regulation, spinning reserve and black start capability;

"Applicant" means the Party that served a Notice of Intention to Refer pursuant to Clause ~~Error! Reference source not found.~~21.2.

"Asset Transfer Date" has the meaning given in Clause 20.9.6.

"Authority" means the Energy and Water Utilities Regulatory Authority established under the Energy and Water Utilities Regulatory Authority Act, Cap. 414, (the "EWURA Act") and the Electricity Act, Cap. 131, (the "Electricity Act")

"Base Rate" means the rate identified as the Base Rate in Schedule 1 -. Whenever the Base Rate is applied, the interest shall be compounded [DAILY], computed for the actual number of Days elapsed on the basis of a 365-Day Year.

"Backup Metering System" has the meaning ascribed thereto in Clause 8.1.2.

"Business Day" means any Day other than a Saturday or a Sunday, on which business by and between banks may be carried out and which is not a national public holiday in Tanzania.

"Change in Law" means the occurrence of any of the following after the Effective Date which materially and adversely affects the original economic equilibrium of the project or the ability of the Project Company to perform its obligations under this agreement:

- (a) the enactment of any new Applicable Laws;
- (b) the repeal, amendment of any existing Applicable Laws;
- (c) the commencement of any Applicable Laws which has entered into effect after the Effective Date;
- (d) a change in the interpretation or any application of any Applicable Laws by a judgement of a court of record which has become final, conclusive and binding or by the competent Governmental Authority, as compared to such interpretation or application by the court of record prior to the Effective Date; or
- (e) any change in the rates of any of the Taxes that have a direct effect on the Project.

"Change Order" means any change order to be given to the Construction Contractor under the Construction Contract which relates to a component of the physical work-in-progress at the Site and which is an Amended Project Document.

"Combined Cycle Operation" means the operation of both a geothermal turbine and a steam turbine at the Plant.

"Commencement of Construction" means the initiation of the construction of the Plant as evidenced by the Seller's (a) issuance of a notice to proceed and (b) making of the Initiation Payment.

"Commercial Operations Date" means the date on which:

- (a) the Conditions Precedent (CP) Satisfaction Date has occurred; and

- (b) [the Open Cycle Operation is Commissioned in accordance with Schedule 3 -, if two step operation is agreed in Minimum Functional Specifications of Schedule 1-./[the entire Plant is Commissioned in accordance with Schedule 3 -.]

"Commissioned" means the state or act of successful completion of Commissioning of the Plant.

"Commissioned Dependable Capacity" means the Dependable Capacity of the Plant as established at the Commercial Operations Date in accordance with Clause 10.9.13.2 and Schedule 3 -.

"Commissioned Shortfall" means the difference between (a) the Commissioned Dependable Capacity if less than the Contracted Dependable Capacity and (b) the Contracted Dependable Capacity.

"Commissioning" means engaging in the operations required for testing of the Plant in accordance with Schedule 3 -.

"Conditions Precedent" or **"CP"** means the conditions precedent specified in Clause 3 and Schedule 9 - of this Agreement

"Confidential Information" has the meaning ascribed thereto in Clause 24.6.

"Construction Contract" means the agreement to be entered into by the Seller for the design, manufacture, construction and Commissioning of the Plant.

"Construction Contractor" means the party or parties to the Construction Contract other than the Seller.

"Construction Contract Price" means the price for the design, manufacture, construction and Commissioning of the Plant specified under the Construction Contract.

"Construction Security" has the meaning ascribed thereto in Clause 12.5.1

"Contracted Dependable Capacity" means the capacity in MW identified as the Contracted Dependable Capacity in Schedule 1 - .

"Contractor" means any contractor employed by the Seller in the design, manufacture, construction, operation or maintenance of the Plant or any part thereof.

"Control Centre" means the Purchaser's system control centre located at [LOCATION] in Tanzania, or such other control centre designated by the Purchaser from time to time (but not more than one at any time) from which the Purchaser shall dispatch the Plant.

"Convention" has the meaning ascribed thereto in Clause 21.3.1.

"CP Satisfaction Date" means the date on which all Conditions Precedent have been satisfied or waived in accordance with this Agreement.

"Complex" means the geothermal electricity generation facility located at the project site and comprising all units, machinery and equipment, within the boundaries of the Project Site, all associate buildings, structures, roads on the Project site that are not Regional, Rural and Urban roads and other appurtenances, together with all required interface to be constructed for the safe, efficient and timely Operation of that facility.

"Damages" means any actual damages agreed upon by the Parties or established pursuant to any dispute resolution procedure described in Clause 21.

"Day" means any twenty-four (24) hour period beginning and ending at 12:00 midnight in Tanzania.

"Declared Available Capacity" means the estimated net capacity of the Plant declared [daily] by the Seller pursuant to Clause 9.4.2 which shall equal the Dependable Capacity of the Plant expressed in MW at the Interconnection Point, adjusted for expected temperature conditions, less any reductions due to Scheduled Outages, Forced Outages, and Maintenance Outages.

"Default Rate" means the Base Rate plus the Margin percent per annum. Whenever the Default Rate is applied, the interest shall be compounded [DAILY], computed for the actual number of Days elapsed on the basis of a 365-Day Year.

"Deemed Energy" means the Net Delivery Energy that the Seller is capable of generating but did not generate, or that the Seller generated but could not deliver to the Delivery Point, due to inability or failure of the Purchaser to receive the Net Delivery Energy.

"Dependable Capacity" means the sustained capacity in MW from the Plant as declared by the Seller in writing to the Purchaser according to Clause 10.3.

"Depreciated Book Value" or **"DBV"** has the meaning given in [Part 1 of Schedule 11 -

"Dispatch" means the instructions issued by the Purchaser from the Control Centre in accordance with this Agreement for the Seller to schedule and control the generation of the Plant in order to increase or decrease the electricity delivered to the Purchaser's Grid System.

"Dispute" has the meaning ascribed thereto in Clause 21.1.

"Effective Date" means the date on which the date on which all conditions precedent specified in Clause 3 and Schedule 9 - are satisfied or duly waived in writing by the party entitled to their benefits.

"Emergency" means a condition or situation that, in the reasonable opinion of either Party, does materially and adversely, or is likely materially and adversely to (a) affect the ability of the Purchaser to maintain safe electrical service to its customers, having

regard to then-current standard of electrical service provided to its customers, or (b) present a physical threat to persons or property.

"Energy Charge" means the price which the Purchaser will pay to the Seller per kWh for Net Energy Output in accordance with Clause 12.2 as determined in accordance with Schedule 5 - hereto.

"Energy Payment" has the meaning ascribed thereto in Clause 12.2

"Environment" means all or any of the following media, namely air (including air within buildings or other natural or man-made structures above or below the ground), water, land, flora, fauna and/or human beings, and "Environmental" shall be construed accordingly.

"Environmental Regulations" means any Law of Tanzania which has as a purpose or effect the protection of or the prevention of harm or damage to the Environment or to provide remedies in relation to harm or damage to the Environment.

"Excepted Assets" means assets listed under Clause 21.4 of this Agreement and any other assets protected by diplomatic and consular privileges under the 1978 State Immunity Act, Cap 33 of the Laws of the United Kingdom and the 1976 Foreign Sovereign Immunities Act of the United States or any successor or analogous legislation.

"Fair Market Value" or **"FMV"** has the meaning given in [Part 1 of Schedule 11 -].

"Finance Parties" means the lenders and other finance parties/party to the Loan Documents and the persons who, from time to time, make other credit facilities available to the Seller, together, in each case, with their respective successors and Permitted Assignees.

"Financial Closing" means the signing of the Loan Documents and the fulfilment of all conditions precedent to the initial availability of funds thereunder.

"Financial Year" means the period from 1 January to 31 December or such other period as may be selected by the Seller and which is acceptable to the Tanzanian tax authorities.

"Forced Outage" means any partial or complete interruption of [a Unit's][the Plant's] generating capability that is not the result of (a) a request by the Purchaser in accordance with this Agreement; (b) a Scheduled Outage or a Maintenance Outage; or (c) an event or occurrence of Force Majeure.

"Force Majeure" means an event or occurrence specified in Clause 17.

"Force Majeure - Natural" has the meaning ascribed thereto in Clause 18.1.1.

"Force Majeure - Political" has the meaning ascribed thereto in Clause 18.1.2.

"Foreign Currency" means the lawful currency of any territory other than Tanzania.

"Foreign Investor" means any Initial Shareholder of the Seller who is a non-resident of Tanzania.

"Foreign Political Events" has the meaning ascribed thereto in Clause 18.1.2.2.

"Fuel" means the fuel identified in Schedule 1 -

"Fuel Supply Agreement" means any agreement entered into by the Seller for the purchase and sale of Fuel.

"GoT" or **"Government"** means the government of the United Republic of Tanzania.

"Government Authority" means GoT and any subdivision thereof, or local government authority with jurisdiction or authority over the Seller, the Contractors, the Finance Parties or the Project or any part thereof, any department, authority, instrumentality, agency or judicial body of GoT or local government authority, and any court, tribunal or independent regulatory agency or body in Tanzania having jurisdiction over the Seller, the Contractors, the Finance Parties or the Project or any part thereof.

"Implementation Agreement" means the Implementation Agreement dated [] entered into between GoT and the Seller.

"Independent Engineer" means an independent consulting engineer, or engineering Seller, of international repute acceptable to the Purchaser, the Seller and the Finance Parties [selected from the list included in Schedule 6 -] for the purposes of monitoring the construction and certifying the results of Commissioning.

"Initiation Payment" means the Seller's first payment to the Construction Contractor under the Construction Contract which shall be at least [] percent of the original Construction Contract Price.

"Initial Shareholders" means the shareholders of the Seller identified in Schedule 10 -.

"Initial Period" means the term identified as such in Clause 2.3.

"Interconnection Facilities" means all the facilities on the high-voltage side of the step-up transformer described in Schedule 2 - to be constructed by or for the Purchaser to enable it to receive and deliver capacity and energy in accordance with this Agreement plus the Metering System.

"Intermediate Period" means the period, if any, from the Commercial Operating Date until the beginning of the Operation Period.

"kV" means 1,000 Volts.

"kVA" means 1,000 Voltamperes.

"kW" means Kilowatts.

"kWh" means Kilowatt-hours.

"Lapse of Consent" means any Permit (a) ceasing to remain in full force and effect, or (b) at any time prior to the [Target CP Satisfaction Date]/[Financial Closing]/[Commencement of Construction]/[Commercial Operations Date], not being issued or renewed upon application having been properly and timeously made and diligently pursued, or (c) from and after the [Target CP Satisfaction Date]/[Financial Closing]/[Commencement of Construction]/[Commercial Operations Date], not being issued or renewed within the period of time prescribed by applicable Laws of Tanzania as applied in a non-discriminatory manner and, in any event, within []Months after the date of proper and complete application thereof, or (d) being made subject, subsequent to its grant, upon renewal or otherwise, to any terms or conditions that materially and adversely affect the Seller's and/or the Contractors' ability to perform its or their obligations (including the making available by the Seller of Dependable Capacity and Net Energy Output as described in Clause 2) under any material document included in the Security Package; provided, however, that in no event shall any Lapse of Consent occur as a result of the GoT or any Government Authority exercising any power pursuant to the Laws of Tanzania to take any of the actions referred to in sub-sections (a) to (d) above as a result of the Seller or any other party to whom a Permit is granted failing to abide by any term or condition of any Permit or as a result of a failure on the part of the Seller or such other party to properly and timeously apply for and diligently pursue the issuance or renewal of any Permit.

"Law" means any law, act, requirement (including licence and permit requirements), ordinance, code, order, rule, resolution or regulation of any governmental authority or agency (federal, national, provincial, municipal, local or other) that is at any time applicable to the Seller, the Plant, the Project, the Site, or any part thereof, and shall include the Laws of Tanzania and all applicable environmental standards and hazardous waste laws, as any such law, act, requirement, ordinance, rule, resolution or regulation or standard may be amended from time to time.

"Laws of Tanzania" means the national, provincial and local laws of Tanzania, all orders, rules, regulations, executive orders, decrees, policies, judicial decisions, notifications or other similar directives made pursuant thereto, as such laws, orders, rules, regulations, decrees, policies, judicial decisions and notifications or other similar directives may be amended from time to time.

"Lenders" means the Project lesser (in a sale/lease back transaction) or the entities that finances or persons providing construction or permanent financing to the Seller in connection with installation of the Project.

"Liquidated Damages Due Date" has the meaning ascribed thereto in Clause 12.8.1.

"Liquidated Damages Notice" means the written notice computing the amount of liquidated damages payable by the Seller or the Purchaser (as the case may be) which has to be sent to the Seller or the Purchaser (as the case may be) following the occurrence of an event justifying the payment of liquidated damages.

"Loan Documents" means the loan agreements, notes, indentures, security agreements, interest rate hedging agreements, guarantees and other documents entered or to be entered into relating to the construction and permanent financing (including financing of working capital requirements and refinancing and provision of letters of credit for construction and permanent financing) of the Plant or any part thereof.

"Local Currency" means the legal tender of Tanzania.

"Maintenance Outage" means an interruption or reduction of a Unit's or the Plant's generating capability that (a) is not a Scheduled Outage; (b) has been scheduled and allowed by the Purchaser in accordance with Clause 9.6; and (c) is for the purpose of performing work on specific components, which work could be postponed by at least [] Days but should not be postponed until the next Scheduled Outage.

"Margin" means the rate identified as the Margin in Schedule 1 -.

"Metering Point" means the point identified as the [metering point] in the diagram at Schedule 2 -.

"Metering System" means all meters and metering devices used to measure the delivery and receipt of Net Energy Output and Dependable Capacity.

"Minimum Functional Specifications" means the minimum functional specifications (including the technical limits of the Plant) for the construction and operation of the Plant as set forth in Schedule 1 - hereof.

"Month" means a calendar month according to the Gregorian calendar beginning at 12:00 midnight on the last day of the preceding month and ending at 12:00 midnight on the last day of that month.

"MVAR" means Megavars.

"MW" means Megawatts.

"MWh" means Megawatt-hour.

"Net Energy Output" means net energy delivered by the Seller for sale to the Purchaser at the Point of Supply in accordance with the Purchaser's Dispatch as measured in accordance with Clause 8.3.

"Non-Escalable Component" –means the Reference Non-Escalable Component described in **Error! Reference source not found.** as adjusted from time to time during the Term in accordance with **Error! Reference source not found.**.

"O&M Contract" means the agreement between the Seller and the O&M Contractor for the operation and maintenance of the Plant.

"O&M Contractor" means the contractor which the Seller may from time to time appoint to operate and maintain the Plant.

"On-Going Dependable Capacity Shortfall" means the amount, if any, by which the Dependable Capacity is below the Commissioned Dependable Capacity.

"Operating Committee" means the committee established pursuant to Clause 9.10 for the purpose of determining operating standards and procedures for the Plant.

"Operations Security" has the meaning ascribed thereto in Clause 12.7.1.

"Operating Year" means that period of time (i) with respect to the first Operating Year of the Project, beginning on the Commercial Operations Date and ending at 11:59 p.m. on the day preceding the first anniversary of the Commercial Operations Date; (ii) with respect to succeeding Operating Years until the last Operating Year, a full Year beginning on each anniversary of the Commercial Operations Date; and (iii) with respect to the last Operating Year, that period of time from the end of the preceding Operating Year through the termination date of this Agreement.

"Open Cycle Operation" means the operation of only a geothermal turbine of the Plant.

"Operation Period" means:

- (a) if the Commercial Operation Date occurs on the first of a Month, the period beginning on that date and ending at the end of Term; or
- (b) If applicable, the Operations Period will commence on the Commercial Operation Date and will terminate at 23:59 hours on the last date of the Month in accordance with its terms and shall continue in full force and effect until the twentieth (20th) anniversary of the Commercial Operations Date as such date may be extended pursuant to Clause 2.4.

"Original Project Documents" means the initial documents of the projects referred to under Clause 4.2.1.

"Parties" means both the Purchaser and the Seller.

"Party" means either the Purchaser or the Seller.

"Payment Dispute Notice" has the meaning ascribed thereto in Clause 12.8.3.

"Peak Months" means the Months of [□].

"Permits" means all such permits, approvals, consents, authorizations, grants or certificates of registration, notifications, concessions, acknowledgments, agreements, licences, decisions or similar items required to be obtained from any Government Authority or other relevant governmental entity for the Seller or for the construction, financing, ownership, operation and maintenance of the Plant.

"Permitted Assignees" means [□]

"Plant" means the generating facility identified as the Plant in the Background section of this Agreement and as further identified in Schedule 1 -.

"Plant Hour" means each hour in which the Plant, but for a Scheduled Outage, would be operating.

"Plant Output Profile" means the record of Plant output measured at the Metering Point in [one minute] intervals.

"Point of Interconnection" means the point at which the Plant is connected to the Purchaser's transmission network, beyond which all assets and equipment are owned and operated by the Purchaser, as described in Schedule 2 -.

"Point of Supply" or "Delivery Point" is the location on the Purchaser's transmission network, at which the ownership of energy transfers from the Seller to the Purchaser. Unless otherwise agreed between the Parties, the Point of Supply shall be the Metering Point.

"Pre-Operation Period" means the period from the date of signing of this Agreement until the Commercial Operation Date.

"Project" means the development, design, engineering, manufacture, financing, acquisition of the Site, construction, permitting, completion, testing, Commissioning, insurance, ownership, operation and maintenance of the Plant and all activities incidental thereto.

"Project Debt" means the aggregate of:

- (a) all amounts outstanding at the Termination Date, including (but not limited to) principal and interest (whether unpaid, compounded or accrued) as at that date including, without limitation, all amounts representing capitalised interest and all amounts that have been advanced to meet any cost overruns or otherwise, from the Seller to the Finance Parties under the Loan Documents, as well as any fees, charges and expenses payable by the Seller to the Finance Parties;
- (b) all amounts, including amounts arising pursuant to closing out, settling early or unwinding any positions under any hedging agreements, and other breakage costs, payable by the Seller to the Finance Parties or the hedging counterparty as a result of a prepayment under the Loan Documents, subject to the Seller and the Finance Parties mitigating all such costs to the extent reasonably possible,

less

- (c) all credit balances held on any bank accounts held by or on behalf of the Seller on the Termination Date which are available for application in or towards the discharge of the amounts referred to in (a) and (b) above on the Termination Date; and
- (d) all amounts payable by the Finance Parties or the hedging counterparty to the Seller as a result of a prepayment of amounts outstanding under the Loan Documents.

"Project Documents" means the documents identified as Project Documents in Schedule 1-.

"Prudent Electrical Utility Practices" means the use of equipment, practices or methods, as required to comply with applicable industry codes, standards, and regulations in Tanzania (i) to protect the Purchaser's system, employees, agents, and customers from malfunctions occurring at the Complex and (ii) to protect the Complex and the Seller's employees and agents at the Complex, from malfunctions occurring on the Purchaser's system;

"Prudent Utility Practices" means the prudent utility practices followed from time to time by the electric utility industry in the United Kingdom, as such practices may be applicable in Tanzania, having regard to engineering, environmental, safety, reliability and operational considerations, including manufacturers' recommendations;

"Purchaser Event of Default" means an event described in Clause 20.2.

"Purchaser Grid System" means the Interconnection Facilities and any other transmission or distribution facilities on the Purchaser's side of the Point of Interconnection(s) through which the Purchaser will distribute the Net Energy Output of the Plant to users of electricity.

"Reactive Power" means the magnetising component of the product of voltage and current, which the Plant shall provide to or absorb from the Purchaser Grid System and which is measured in (Megavolt Ampere Reactive (MVAR)).

"Reasonable and Prudent Operator" means an operator who follows the practices generally followed from time to time by the electric utility industry (including practices generally followed by independent power producers) in [Tanzania], having regard to engineering and operational considerations, including manufacturers' recommendations, the practices are not limited to optimum practices, methods or acts to the exclusion of all others, but rather are a spectrum of possible practices, methods and acts which could have been expected to accomplish the desired result at reasonable cost consistent with reliability and safety.

"Reference Exchange Rate" means the official rate of exchange recognised by the central bank of [Tanzania] for the conversion of the Local Currency into [USD].

"Required Commercial Operations Date" means the date on which the Plant is required to be Commissioned as identified in Schedule 1 -.

"Respondent" means the Party on whom a Notice of Intention to Refer has been served in accordance with Clause 21.2.

"SCADA System" means a system to be used for supervisory control and data acquisition

"Scheduled Commercial Operations Date" means the date which the Seller identifies to the Purchaser as the date the Plant will be Commissioned, as such date may be revised from time to time based on the scheduled construction program.

"Scheduled Outage" means a planned partial or complete interruption of the Plant's generating capability that (a) is not a Maintenance Outage; (b) has been scheduled and allowed by the Purchaser in accordance with Clause 9.5; and (c) is for inspection, testing, preventive maintenance, corrective maintenance or improvement.

"Security Package" means all of the agreements identified in Schedule 8 - that are entered into in furtherance of the design, financing, construction, ownership, operation and maintenance of the Plant and that form part of the security granted to the Finance Parties.

"Seller Event of Default" means an event described in Clause 20.1.

"Signature Date" means the date on which this Agreement is signed by the Parties;

"Site" means the land, spaces, roads, water wells and any rights acquired or to be acquired by the Seller for the purposes of the Plant on, through above or below the ground on which all or on any part of the Plant is to be built, (including any working areas required by the Seller and the Contractors, villages, townships and camps for the accommodation of the employees of the Seller and the Contractors, and all rights of way and access from public highways and, where applicable, railway and seaward access) [as further described in Schedule 1 -].

"Start-Up" means after the Commercial Operations Date, any start-up of a [Unit] or the Plant that is requested by the Purchaser and that results in synchronization with the Purchaser Grid System. Any such Start-Up shall include one.

"Supplemental Payments" means the amount which the Purchaser will pay to the Seller per Month for [□] in accordance with Clause 12.2 as determined in accordance with Schedule 5 -hereto.

"Tanzania" means the United Republic of Tanzania.

"Tanzania Political Events" has the meaning ascribed thereto in Clause 18.1.2.1.

"Target CP Satisfaction Date" means the date identified as the Target CP Satisfaction Date in Schedule 1 -.

"Term" means the term of this Agreement, as determined in accordance with Clause 2

"Termination Amount" means the amount, determined in accordance with [Schedule 11 -], which shall be paid by the Purchaser to the Seller in the event of the early termination of this Agreement.

"Termination Date" means the date of the expiry of the Term, or the date of the earlier termination of this Agreement, as the case may be.

"Termination Notice" means a written notice served by one Party on the other Party, stating its decision to immediately terminate this Agreement and the grounds for termination, by reference to its right to terminate as set out in this Agreement.

"Termination Payment" has the meaning given in [Part 2 of Schedule 11 -].

"Total Project Costs" shall mean the actual cost (calculated in [the Local Currency]) of developing, designing, building, financing, insuring, and commissioning the Plant.

"Transferred Assets" has the meaning given in Clause 20.7.4.

"Transfer Benefits" has the meaning given in [Part 1 of Schedule 11 -].

"Transfer Liabilities" has the meaning given in [Part 1 of Schedule 11 -].

"Transfer Notice" has the meaning given in Clause 20.6.1.

"Transfer Value" means the value or values set out in paragraph 1 of [Part 1 of Schedule 11].

"Two Step Operation" means Commissioning of Open Cycle Operation first, followed by subsequent Commissioning of Combined Cycle Operation.

"Unit" means each of the generating units that forms a part of the Power Plant.

"Valuer" has the meaning given in Clause 20.9.2.

"Week" means each period of seven consecutive Days beginning at 12:00 midnight Tanzania time falling between a Saturday and a Sunday.

"Year" means each 12 Month period commencing on 00:00 midnight on a given date and ending on 00:00 of the first anniversary of that date.

1.2 Interpretation

In this Agreement, unless the context otherwise requires:

- 1.2.1 terms not herein defined shall have the meanings ordinarily ascribed thereto in the Oxford English Dictionary;
- 1.2.2 all references herein to time are to Tanzania time;
- 1.2.3 references to any document (including this Agreement) are references to that document as amended, consolidated, supplemented, novated or replaced from time to time, and to all annexes, schedules, attachments, supplements and the like which form part thereof;
- 1.2.4 terms defined in any number, gender or tense shall have the correlative meaning when used in any other number, gender or tense;
- 1.2.5 an **"encumbrance"** shall be construed as a reference to a mortgage, charge, pledge, lien or other encumbrance securing any obligation of any person or any other type of preferential arrangement (including, without limitation, title transfer and retention arrangements) having a similar effect;

- 1.2.6 the words "**include**", "**including**" and "**in particular**" indicate examples or emphasis only and shall not be construed as limiting the generality of any preceding words;
- 1.2.7 the words "**or other**" or "**otherwise**" shall not be construed as limiting the generality of any preceding words where a broader interpretation is possible;
- 1.2.8 reference to persons means any individual, association, trust, joint venture, unincorporated association, consortium, partnership (whether or not having separate legal personality), corporation, firm, government, including the GoT and any Government Authorities, party to this Agreement wherever organised or incorporated and whether or not having separate legal personality; and references to any person, including any Party hereto, shall include that person's successors in title, permitted assignees, transferees, delegates, sub-delegates or appointees (unless the transfer to the successor in title or transferee was in breach of this Agreement);
- 1.2.9 where this Agreement defines a word or expression, related words and expressions have a consistent meaning;
- 1.2.10 all periods of time and dates shall be based on and computed according to the Gregorian calendar and times of Day are times of the Day in Tanzania;
- 1.2.11 in the computation of periods of time from a specified Day to a later specified Day, from means from and including and until or to means to and including;
- 1.2.12 references to any clause, paragraph, Part, Schedule or recital are to those contained in this Agreement;
- 1.2.13 the expression "this Clause", unless followed by the number of a specific part of the clause, refers to the whole clause in which it occurs;
- 1.2.14 the table of contents, clause and schedule headings are inserted for convenience only and shall not affect the interpretation or construction of this Agreement; [and
- 1.2.15 "**written**" or "**in writing**" includes faxes but not email].

1.3 Schedules

All the Schedules are an integral part of this Agreement.

2. TERM

2.1 Term

- 2.2 This Agreement shall consist of an Initial Period and an Operations Period. As used herein, "Term" shall mean all the Initial Period and the Operations Period, unless the

Seller or the Purchaser terminates the Agreement prior to the end of the Initial Period pursuant to the terms of this Agreement.

2.3 Initial Period

The Initial Period will begin on the date set forth above and will terminate on the earlier of (i) the Commercial Operation Date, or (ii) the Date the Agreement is terminated pursuant to the provisions of Clause 20.

2.4 Operations Period

If applicable, the Operations Period will commence on the Commercial Operation Date and will terminate at 23:59 hours on the last date of the Month in which the twentieth (20th) anniversary of the Commercial Operation Date occurs.

2.5 [Extension of Term due to Force Majeure

The Term shall be automatically extended by the aggregate periods allowed for the performance by the Parties of obligation(s) referred to in Clause 18].

2.6 Extension of Term

The Term may be extended, subject to agreement in writing by parties to such extension prior to the expiry date.

3. CONDITIONS PRECEDENT

3.1 Seller Conditions Precedent

Subject to Clause 3.4, the Seller shall have satisfied or shall have caused to have satisfied the Conditions Precedent in Part A of Schedule 9 - by the Target CP Satisfaction Date.

3.2 Purchaser Conditions Precedent

Subject to Clause 3.4, the Purchaser shall have satisfied or shall have caused to have satisfied the Conditions Precedent in Part B of Schedule 9 - by the Target CP Satisfaction Date.

3.3 Progress review

3.3.1 The Parties shall diligently use their reasonable endeavours to achieve satisfaction of their respective Conditions Precedent and shall cooperate in good faith with the other Party towards the satisfaction of its Conditions Precedent.

3.3.2 The Parties shall jointly review the progress towards achieving satisfaction of the Conditions Precedent on a [monthly] basis or whenever necessary and shall notify each other promptly of each event which may delay the Conditions Precedent to be satisfied by the Target CP Satisfaction Date. The Seller shall promptly, upon the satisfaction of the Conditions

Precedent set out in [Part A] of Schedule 9 -, give the Purchaser written notice that such Conditions Precedent have been satisfied and the Purchaser shall promptly, upon the satisfaction of the Conditions Precedent set out in [Part B] of Schedule 9 -, give the Seller written notice that such Conditions Precedent have been satisfied.

3.4 Delay

If the Conditions Precedent have not been satisfied or waived by the Target CP Satisfaction Date:

3.4.1 the Parties may agree to extend the period by which the Conditions Precedent have to be satisfied or waived; or

3.4.2 either Party may immediately terminate this Agreement by serving a Termination Notice on the other Party, in which case either Party shall be discharged from any further obligations under this Agreement save for those liabilities which have accrued and any rights and obligations expressed to arise upon or survive such termination.

4. PRE-OPERATION PERIOD

4.1 Permits and Licences

4.1.1 The Seller, at its sole cost and expense, shall, as soon as reasonably practicable but in any event no later than the Scheduled Commercial Operation Date:

- (a) acquire and maintain in effect all Permits required by all Government Authorities with jurisdiction over the Seller and/or the Plant in order to enable it to perform its obligations under this Agreement;
- (b) give all required notices and allow all required inspections under all Permits obtained by it in connection with the Plant; and
- (c) pay all prescribed fees in connection with such Permits.

4.1.2 The Purchaser, at its sole cost and expense, shall, as soon as reasonably practicable but in any event no later than the Scheduled Commercial Operation Date:

- (a) Use all reasonable endeavours to acquire and maintain in effect all Permits required by all Government Authorities with jurisdiction over the Purchaser and/or the Purchaser Grid System in order to enable it to perform its obligations under this Agreement;

- (b) give all required notices and allow all required inspections under all Permits obtained by it in connection with the Purchaser Grid System; and
- (c) pay all prescribed fees in connection with such Permits.

4.1.3 The Seller shall submit to the Purchaser:

- 4.1.3.1 on or before Financial Closing, copies of all Permits and other governmental authorizations that have been issued to the Seller to date for the design, financing, construction, ownership, operation and maintenance of the Plant;
- 4.1.3.2 at least fifteen (15) Days prior to Commencement of Construction, evidence demonstrating that the Seller has, or the Construction Contractor or other Contractors have, obtained all Permits that are necessary for the Commencement of Construction, including the permit to use a water resource; and
- 4.1.3.3 not later than fifteen (15) Days prior to the Commercial Operations Date:
 - (a) evidence demonstrating that the Seller has obtained all of the Permits then required to be obtained for the ownership, operation and maintenance of, and the supply of power from, the Plant; and
 - (b) a list identifying Permits not yet required to be obtained for the operation and maintenance of, and the supply of power from, the Plant, together with a plan reasonably acceptable to the Purchaser for obtaining such Permits and an estimate of the time within which such Permits will be obtained.

4.2 **Documents to be provided by the Seller**

4.2.1 The Seller shall submit to the Purchaser the Original Project Documents listed below on or before the dates specified :

Contracts and similar documents

- 4.2.1.1 as soon as available, but no later than Financial Closing, a copy of the Implementation Agreement as executed, with any amendments thereto;
- 4.2.1.2 on or before Financial Closing, a copy of the Construction Contract as executed, including all schedules, plans, and specifications attached thereto, plus all amendments executed as of that date;

- 4.2.1.3 on or before Financial Closing, executed copies of the Fuel Supply Agreement, fuel transportation agreement, backup fuel agreement and other commitments for the supply and transportation of Fuel and backup fuel;
- 4.2.1.4 as available, draft copies of the agreement for the supply of backup Fuel for the Plant, and no later than fifteen (15) Days prior to Financial Closing, a copy of such backup Fuel supply agreement, as it will be executed on or before Financial Closing;]
- 4.2.1.5 as soon as available, copies of any contracts executed with Direct Contractors;

Documents related to the operations

- 4.2.1.6 on or before Financial Closing, a copy of the Seller's proposed plan for the operations and maintenance of the Plant or an O&M Contract entered into by the Seller, together with all amendments executed as of that date;
- 4.2.1.7 as soon as available, but no later than the Financial Closing, the Seller shall provide the Purchaser with any environmental assessment or study relating to the Plant that has been approved by Government Authority and provided to the Seller or to its Finance Parties;
- 4.2.1.8 as soon as available but not later than thirty (30) Days after Financial Closing, general arrangement drawings for the construction of the Plant;
- 4.2.1.9 not later than fifteen (15) Days prior to the scheduled commencement of testing and Commissioning, a start-up and test schedule for the Plant;
- 4.2.1.10 not later than thirty (30) Days prior to the Required Commercial Operations Date, a copy of draft written operating procedures to serve as the basis for the written operating procedures to be developed pursuant to Clause 4.5;
- 4.2.1.11 as soon as available but not later than the Commercial Operations Date, final design drawings for the construction of the Plant;
- 4.2.1.12 as soon as available but not later than fifteen (15) Days after the Commercial Operations Date, copies of all test results for tests performed on the Plant;
- 4.2.1.13 as soon as available but not later than the Commercial Operations Date, a certificate signed by the Independent

Engineer stating that he has supervised the design and construction of the Plant as a Reasonable and Prudent Operator and that, to the best of his knowledge, such design and construction has been completed consistent with the terms of this Agreement (including the Minimum Functional Specifications), the Implementation Agreement, the Fuel Supply Agreement, the Construction Contract, the final design drawings, and that the Plant will have a useful life of at least twenty five (25) Years;

4.2.1.14 not later than thirty (30) Days following the Commercial Operations Date for the major items of plant incorporated into the Plant:

(a) copies as received by the Seller under the Construction Contract of all the manufacturers' specifications and manufacturers' operation manuals; and

(b) a certificate of the Independent Engineer attesting to the fact that all equipment is new and unused; and

4.2.1.15 as soon as available but not later than []Months after the Commercial Operations Date, As-built drawings and complete specifications for the Plant.

4.2.2 Neither the receipt nor approval of any Original Project Document or Amended Project Document (defined below) shall:

4.2.2.1 relieve the Seller of any liability, obligation or responsibility under this Agreement or the Implementation Agreement resulting from a breach by the Seller or its Contractors of this Agreement or the Implementation Agreement; or

4.2.2.2 be construed as an endorsement by the Purchaser of the layout, design, financing, construction, ownership, operation or maintenance of the Plant nor as a warranty by the Purchaser of the safety, durability or reliability thereof.

4.3 Changes to existing documents

4.3.1 The Seller shall provide to the Purchaser Amended Project Documents in a timely manner as such information is amended, modified or superseded and all such supplements and amendments.

4.3.2 Prior to executing (a) any Original Project Document or (b) any Amended Project Document [that is material to the interests of the Purchaser under this Agreement], the Seller shall obtain the written approval of the Purchaser, provided that any such approval requested from the Purchaser for an Amended Project Document which is to be executed or otherwise created after Financial Closing shall be deemed given unless refused

within thirty (30) Days after notice of the request for such approval, or, in the case of Change Orders, within fifteen (15) Days after notice of the request for such approval.

4.4 Progress Reports

- 4.4.1 Beginning within forty-five (45) Days after Financial Closing and ending on the Commercial Operations Date, the Seller shall submit to the Purchaser:
 - 4.4.1.1 monthly progress reports substantially in the form set forth in Schedule 7 -- (or such other form as may be agreed to by the Parties);
 - 4.4.1.2 such other reports as are submitted to the Seller by the Independent Engineer; and
 - 4.4.1.3 reports, when and as the Seller becomes aware, of any new condition or event which will have a material and adverse effect on the timely completion of the Plant.

4.5 Operating Procedures

- 4.5.1 Within thirty (30) Days of the establishment of the Operating Committee, the Parties shall cause the Operating Committee to meet and cause their respective designated members to finalize the Operating Procedures addressing all operational interfaces between the Purchaser and the Seller. The Operating Procedures shall:
 - 4.5.1.1 take proper account of the design of the Complex, the Metering Systems, and the Grid System; and
 - 4.5.1.2 be consistent with Prudent Electrical Utility Practices, Prudent Utility Practices, and the Technical Limits.
- 4.5.2 The procedure for developing and finalising the Operating Procedures shall be as follows:
 - 4.5.2.1 Within thirty (30) Days following the establishment of the Operating Committee, the Seller shall deliver to the Purchaser in writing proposed draft Operating Procedures;
 - 4.5.2.2 the Purchaser shall provide comments in writing on the draft Operating Procedures within fifteen (15) Days following the date the draft Operating Procedures are delivered by the Seller to the Purchaser, and each Party shall make a representative available to meet within seven (7) Days following the end of such seven (7) Day period to review each Party's comments on

- the draft Operating Procedures and on the proposed changes and any objections to the proposed changes of a Party.
- 4.5.2.3 As soon as is practicable after the meeting referred to in Clause 4.5.2.2, but in any event within seven (7) Days following the end of such meeting, the Seller shall provide the Purchaser with proposed final draft Operating Procedures, incorporating to the extent agreed each of the Parties' proposed changes;
- 4.5.2.4 the Purchaser shall provide final comments on the final draft Operating Procedures within seven (7) Days after its receipt by the Purchaser and, within seven (7) Days after a request from the Seller, the Purchaser shall make its representatives available to meet at a venue to be mutually agreed by the parties, and review its comments and proposed changes with the Seller; and
- 4.5.2.5 the Seller shall revise the draft Operating Procedures to incorporate such additions or modifications required by the Purchaser and shall provide a final draft to the Purchaser as soon as practicable, and in any event within seven (7) Days following receipt of the Purchaser's comments and proposed changes to the draft Operating Procedures. Any Dispute between the Parties as to whether any matter should be included in or excluded from or modified in the way it is then treated in the draft Operating Procedures shall be determined in accordance with Clause 20.2. The determination of the Expert shall be final and binding with respect to the resolution of such Dispute.
- 4.5.3 Following the finalization of the Operating Procedures pursuant to Clause 4.5.2.5, either Party may propose changes to the Operating Procedures from time to time as changes in events and circumstances may require. The Parties shall meet and discuss such proposed changes in good faith and incorporate such changes as are agreed by the Parties. Any Dispute between the Parties as to whether any matter should be included in or removed from or modified in the way it is then treated in the Operating Procedures shall be determined in accordance with Clause 20.2. The determination of the Expert shall be final and binding with respect to the resolution of such Dispute.
- 4.5.4 The Seller and the Purchaser shall mutually develop an inter-tripping schedule no later than sixty (60) Days prior to the required implementation of such schedule. Such inter-tripping schedule shall be based on a proposed schedule submitted to the Seller by the Purchaser at least one twenty (120) Days prior to the date implementation of such schedule is required.
- 4.5.5 The operating procedures shall be deemed to have been developed by the Seller and the prior written consent by the Purchaser in accordance with this Clause 4.5 shall not relieve the Seller of any liability, obligation or

responsibility under this Agreement and shall not relieve the Seller from developing and submitting to the Purchaser sound and reliable operating procedures.

4.6 **Energy Before Commissioning**

4.6.1 Upon the Seller's request, the Purchaser shall provide energy for construction, testing, Commissioning, Start-Ups and Emergencies, subject to availability and the Purchaser's ability to deliver such energy to the Plant. The Seller shall pay the Purchaser for such energy in accordance with the Purchaser's then prevailing tariff rate for industrial facilities.

4.6.2 The Purchaser is hereby authorized to set off the charges for such energy delivered by the Purchaser to the Seller pursuant to Clause 12.1.1 against any Energy Payments due and owing to the Seller.

4.6.3 Prior to the Commercial Operations Date, the Purchaser shall use reasonable efforts to accept all energy produced by the Plant during testing performed pursuant to the Construction Contract and Commissioning, and the Purchaser shall pay the Seller for such energy at the rate set forth in Clause 12.1.1 **Error! Reference source not found.** For the avoidance of doubt, the Purchaser shall not be liable for any Capacity Payments prior to the Commercial Operations Date.

4.7 **Pre-operation inspection**

The Parties agree that:

4.7.1 the Purchaser and/or its representatives shall have the right to observe the progress of the construction of the Plant and the testing and Commissioning of the Plant in accordance with Schedule 3 -;

4.7.2 the Seller shall comply with all reasonable requests of the Purchaser for, and assist in arranging, any such observation visits to the Plant;

4.7.3 such visits to the Plant shall not be construed as an endorsement by the Purchaser of the design thereof or as a warranty by the Purchaser of the safety, durability or reliability of the Plant; and

4.7.4 all persons visiting the Plant on behalf of the Purchaser shall comply with the reasonable instructions and directions of the Seller and/or its Contractors.

4.8 **Pre-operation access to Site**

Upon seven (7) Business Days' prior written notice from the Seller, the Purchaser shall grant the Seller reasonable access during working hours to any lands owned by the Purchaser that are necessary for designing, financing, constructing, operating and maintaining the Plant.

5. GENERAL COVENANTS OF THE SELLER IN RESPECT OF THE PLANT

The Seller hereby covenants as follows:

- 5.1 during the Term, the Seller shall design, finance, construct, own, operate and maintain the Plant in accordance with:
 - 5.1.1 this Agreement;
 - 5.1.2 the Minimum Functional Specifications set forth in Schedule 1 -;
 - 5.1.3 the operating procedures developed pursuant to Clause 4.5;
 - 5.1.4 the environmental guidelines, social safeguard standards and occupational health and safety standards issued by Government;
 - 5.1.5 all applicable Permits and Laws; and
 - 5.1.6 such requirements as the Purchaser may reasonably deem necessary in order for the Interconnection Facilities to be designed and constructed in accordance with sound engineering and construction practices of a Reasonable and Prudent Operator;
- 5.2 the Plant will be designed, constructed, completed, operated and maintained:
 - 5.2.1 in a good and workmanlike manner, only with materials and equipment that are new, utility grade, and suitable for their intended use;
 - 5.2.2 in such a manner as to provide that the useful life of the Plant, with proper operation and maintenance, will be at least equal to thirty (30) Years; and
 - 5.2.3 in accordance with all material respects with sound engineering and construction practices of a Reasonable and Prudent Operator;
- 5.3 the Seller shall test and commission the Plant on or before the Required Commercial Operations Date; and
- 5.4 during the Term, the Seller shall maintain the Site in a clean, safe and presentable manner.

6. CONSTRUCTION OF THE COMPLEX

6.1 Construction of the Complex

- 6.1.1 The Seller shall commence and proceed with the Construction Works as soon as reasonably practicable following the Effective Date. The Seller shall procure that the design of the Construction Works shall be carried out with all proper skill and care and in all material respects in accordance with this Agreement, including the Technical Specifications, the Laws of Tanzania (including the Seller Consents), Prudent Utility Practices and

Prudent Electrical Utility Practices, so that the Complex is reasonably expected to provide a useful life of not less than the Term.

- 6.1.2 The Seller shall carry out and complete the Construction Works such that the Seller is able to achieve the Commercial Operations Date by the Required Commercial Operations Date.
- 6.1.3 The Seller shall cause all equipment which is permanently installed by the EPC Contractor as part of the Complex to be new and unused at the time of such installation and to otherwise comply with the requirements of Schedule 2 -,
- 6.1.4 The Purchaser shall, in accordance with the Minimum Functional Specifications, install protective devices within the Interconnection Facilities having appropriate ratings and characteristics to protect the Purchaser's equipment at the Interconnection Facilities, and, subject to the Minimum Functional Specifications, shall maintain the settings of all such devices at the levels required.
- 6.1.5 At any time during the Initial Period, Seller shall have the right to cease development of the Project on the Premises for any reason, in its sole discretion. If Seller gives Purchaser notice of such determination, this Agreement shall terminate effective as of the delivery of such notice without any further liability of the Parties to each other, provided that:
- (i) Seller shall remove any equipment or materials which the Contractor has placed on the Site;
 - (ii) Seller shall restore any portions of the Site disturbed by Seller to its pre-existing condition;
- 6.1.6 Upon completion of the Interconnection Facilities described in Clause 7.1.1 , the Purchaser shall test such Interconnection Facilities in accordance with the procedures set forth in Schedule 3 -.

6.2 **Submission of Reports and Information**

- 6.2.1 The Seller shall submit, or cause to be submitted, to the Purchaser the following documents on or before the specified dates:
- 6.2.1.1 As soon as available, but no later than the Effective Date, a copy of the Implementation Agreement as executed, with any amendments thereto;
 - 6.2.1.2 Beginning within thirty (30) Days after the Effective Date and ending on the Commercial Operations Date,
 - (a) reasonably detailed Construction Reports delivered to the Purchaser not later than the last Day of March, June,

- September and December, including any updates to the construction milestone schedule contained therein,
- (b) such other reports as are submitted to the Seller by the Engineer, and
 - (c) reports, when and as the Seller becomes aware, of any condition or event and/or any change in such condition or event that will have a material and adverse effect on the timely completion of the construction of the Complex.
- 6.2.1.3 No later than ninety (90) Days after the Effective Date,
- (a) evidence demonstrating that the Seller has obtained all the Seller Consents then required to be obtained for the lease/ownership, construction, operation and maintenance of, and the supply and delivery of Net Electrical Output from, the Complex,
 - (b) a list identifying the Seller Consents not yet required to be obtained for the operation and maintenance of, and the supply and delivery of Net Electrical Output from the Complex, and
 - (c) a list identifying the Seller Consents applied for by the Seller or its Contractors but not yet issued or received, together with a plan reasonably acceptable to the Purchaser for obtaining such Seller Consents and an estimate of the time within which such Seller Consents will be obtained;
- 6.2.1.4 At least sixty (60) Days prior to the scheduled commencement of testing and Commissioning of the Complex, a preliminary start-up and test schedule for the Complex.
- 6.2.1.5 On or before the Commercial Operations Date, a certificate from the Engineer addressed to the Seller and the Purchaser to the effect that, based upon its monitoring and review of construction, the construction of the Complex has been carried out in all material respects in compliance with the terms of this Agreement.
- 6.2.1.6 On or as soon as practicable following the Construction Start Date but in any event within ten (10) Business Days thereafter, a copy of the certificate of insurance for the EPC Contractor's All Risk Insurance Policy and, as soon as available, a copy of such policy, and as soon as is available but in any event on or before the Commercial Operations Date and, as and when updated, copies of all insurance policies and certificates of

- insurance or other certificates of insurance for policies detailed in Clause 13 and Schedule 8 -
- 6.2.1.7 As soon as available, but no later than thirty (30) Days following Commissioning Tests, two copies of all results of the Commissioning Tests, including tests of major equipment included in the Complex, tests of related electricity metering equipment, and a certificate from the Engineer confirming each successful Commissioning Test shall be provided to the Purchaser;
- 6.2.1.8 No later than thirty (30) Days following each successful Commissioning Test, for the major items of plant incorporated into the Complex, one copy, as received by the Seller pursuant to the EPC Contract, of all the manufacturers' specifications and manufacturers' operation manuals; and
- 6.2.1.9 As soon as available, but no later than thirty (30) Days following the successful completion of the Commissioning Tests, two copies of the Commissioning Tests results performed on the Complex, and a certificate from the Engineer confirming the results of each such test.
- 6.2.2 The Seller shall notify the Purchaser promptly from time to time whenever it determines that the then expected date for the Commissioning of the Complex is unfeasible or inappropriate, and shall specify a revised expected date for the Commissioning of the Complex which shall not in any event be earlier than ten (10) Business Days following the date of delivery of such notice to the Purchaser.
- 6.2.3 The Purchaser shall provide to the Seller within thirty (30) Business Days after receipt of a written request from the Seller, documents and information on the Grid System and such other documents and data in the Purchaser's possession and control as may be reasonably necessary for the Seller to undertake the Seller Interconnection Works and the Construction Works, including details of all existing and planned facilities necessary to connect the Complex with the Grid System, dispatch and communications procedures currently in use by the Purchaser and any planned changes to the dispatch and communication procedures then in effect.
- 6.2.4 In connection with the provision of such documents and information referred in Clause 6.2.3, the Purchaser shall allow the Seller during the Purchaser's regular business hours to make copies of such documents and information, at the Seller's sole cost and expense, and to have reasonable access to and to consult with the Purchaser's relevant personnel engaged in the management, operation, maintenance and reinforcement of the Grid System.

- 6.2.5 When such documents and information is no longer required for the purposes provided herein, such documents and information shall be returned to the Purchaser or destroyed by the Seller.
- 6.2.6 Each Party shall notify the other Party in a timely manner upon becoming aware of any changes to the information provided to the other Party pursuant to this Clause 6.2.

6.3 Delivery of Electrical Power

From and after the Completion and Commissioning of the Interconnection Facilities, the Seller shall, to the extent necessary carry out testing of the Complex including Commissioning Tests, transport to the Complex, electrical energy for start-ups in accordance with the schedules provided to the Seller Pursuant to Clause 4.2 6.2 and Clause 8.210.2.

6.4 Purchaser Observation Visits

- 6.4.1 The Purchaser shall have the right, on a recurring basis and upon reasonable prior notice to the Seller to have the Purchaser's officers, employees, and representatives observe the progress of the Construction Works and the Seller Interconnection Works and the operation of the Complex.
- 6.4.2 The Seller shall comply with all reasonable requests of the Purchaser for the visits, and assist in arranging, any such observation visits. The Purchaser's visits shall be reasonable both in terms of the frequency of such visits and the number of persons.
- 6.4.3 All persons visiting the Complex, or the Site on behalf of the Purchaser shall comply with the Seller's and its Contractors' generally applicable safety regulations and procedures made available to such persons and shall comply with the reasonable instructions and directions of the Seller and its Contractors, and shall not unreasonably cause any interference with or disruption to the activities of the Seller or its Contractors on the Site.

6.5 Appointment of the Engineer

- 6.5.1 Not later than two hundred and seventy (270)Days prior to the then-prevailing Scheduled Commercial Operations Date, the Engineer shall have been appointed by the Seller, with the approval of the Purchaser, (and shall by such date be available to perform the duties of the Engineer provided herein and shall thereafter keep appointed and available for as long as may be necessary to discharge the duties of the Engineer under this Agreement) to carry out the duties of the Engineer specified in this Agreement in accordance with the highest professional standards and duty of care, both to the Seller and to the Purchaser. The Seller shall not replace any Person appointed as the Engineer without the prior written consent of the Purchaser.

- 6.5.2 The terms and conditions of appointment of the Engineer shall oblige the Engineer to act independently and impartially, on the basis of his expertise, experience and knowledge in relation to all matters referred to him pursuant to this Agreement and in carrying out his other duties ascribed to him under this Agreement. The costs and remuneration to which the Engineer is entitled under his terms and conditions of appointment shall be borne by the Seller.
- 6.5.3 The Seller and the Purchaser duly recognize that the circumstances existing at the time of tender are not likely to remain the same till the start of construction. Therefore, an independent engineer is required to, authorize variations, deliver opinions or certifications, carry out estimations or valuations and order payments. Not later than thirty (30) Days following the Construction Start, the Seller shall nominate three (3) independent engineering firms or consultants of international repute and notify the names of such firms or consultants to the Purchaser. The Purchaser shall review and evaluate the financial and technical particulars of the nominated firms or consultants in the required area of specialization. Within ten (1) Days of receipt by the Purchaser of the notice, the Purchaser shall either (a) select one of such firms or consultants to be the independent engineering / cost firm or consultant (the “Independent Engineer”) or, (b) object, if in its reasonable and professional judgment, the nominated firms do not fulfil the criteria (as pre-determined in consultation with the Seller). In such an event, the Purchaser shall have the right to appoint the Independent Engineer in consultation with the Seller provided however that if the Purchaser has not notified the Seller of its selection or objection within ten (10) Day period, the Seller shall within five (5) Days following the end of such period appoint one of such three firms or consultants to be the Independent Engineer. The selection and appointment of an Independent Engineer in accordance with this Clause shall be binding on the Parties. The cost of engaging the Independent Engineer during the term of appointment shall be borne by the Seller.
- 6.5.4 The terms of reference of the Engineer shall include but not limited to monitoring and evaluating the re-openers pertaining to any cost variations due to geological conditions limited to the tunnel area, cost escalations in the civil works associated with construction, and re-settlement costs (the “Re-Openers”) which have been identified by the Seller in the feasibility studies, EPC Contract or tariff petition submitted to the Authority (as the case may be) and such identified Re-Openers are thereafter determined or approved by the Authority. The Independent Engineer shall, among others, be required to prepare monthly reports up to the Commissioning Tests (the “Re-Opener Reports”) in accordance with terms of reference including an assessment or valuation or payment (provisional or final) of any reasonable and prudently incurred costs by the Seller for such Re-Openers. The Re-Opener Reports shall be in a form acceptable to the Purchaser and include all necessary details along with supporting documents. The Independent Engineer shall deliver the Re-Opener Reports in the prescribed format to the Purchaser within seven (7) Days following the

end of the month to which the Re- Opener Report relates. The Purchaser shall then review the Re-Opener Report within fourteen (14) days from the date of submission and may seek additional information thereto. After submission of any additional information required by the Purchaser or in case no further information is required the Re-Opener Report shall be considered to be final. Provided however, in case the Purchaser or the Seller/EPC Contractor disagrees with the valuation, payment, opinion, or certification of the Independent Engineer in relation to the Re-Openers, the Parties shall have the right to request re-determination by the Independent Engineer. The Independent Engineer shall then determine the whole or part of total claim in consultation with the parties and is entitled to review or modify opinion, certification, valuation, or payment. Such re-determination of Independent Engineer shall be final and binding on the Parties. Provided further, any opinion, certification, valuation, payment orders etc of Independent Engineer is subject to tariff review guidelines issued by the Regulator at the Commercial Operations Date.

- 6.5.5 For avoidance of doubt any dispute between the Seller and the Purchaser on the contents of the Re-Opener Report submitted by the Independent Engineer shall not constitute Dispute as such term bears the meaning attributable hereto under the Agreement. At the end of construction period the Independent Engineer would be required to submit a certificate indicating readiness of the Complex for Commissioning Tests.

7. INTERCONNECTION

7.1 Interconnection Facilities

- 7.1.1 The Seller shall make all arrangements at its own expense necessary to transmit and deliver the Net Energy Output to the Purchaser at the Delivery Point, and the Purchaser shall cooperate with the Seller in these arrangements.
- 7.1.2 The Seller shall ensure that the project is capable of dispatching Active and Reactive power as per the Dispatch Instructions and of being operated in parallel with the Grid System as per Prudent Utility Practices and relevant technical standards of connectivity with the Grid.
- 7.1.3 The Seller shall ensure delivery of power at the Interconnection Point in a safe and reliable manner so as to avoid fluctuations and disturbances to the Grid System due to parallel operation.

7.2 The Seller's Responsibility

- 7.2.1 The Seller shall at the Seller's own cost design, purchase, construct, operate and maintain the Interconnection Facilities prior to commissioning; and the Seller shall own all such auxiliary and interconnection equipment; the Seller shall pay for the upgrading of equipment in the Purchasers system necessary to enable the delivery of the net electrical output into the Purchaser's system. The design of the

Interconnection Facilities shall be compliant with the Purchaser's equipment, transmission requirements and standards in accordance with the prevailing Grid Code.

7.2.2 Upon completion and commissioning of Interconnection Facilities, the Seller shall transfer to the Purchaser, and the Purchaser shall accept, own and maintain the interconnection facilities, as beneficial owner all rights title and interest therein free of any encumbrances together with all the applicable warranties and guarantees in respect thereof and the Seller shall not be liable to the Purchaser in respect of the Interconnection Facilities from the date of such transfer, provided that –

- (a) The cost of undertaking the design, purchase, construction, installation, testing and commissioning of Interconnection Facilities is deemed included in the Tariff;
- (b) The Seller shall at all times, prior to the transfer to the Purchaser of the Interconnection Facilities, retain responsibility for ensuring the Interconnection Facilities meet the Purchaser's specifications.

7.3 The Purchaser's Responsibility

The Purchaser shall provide to the Seller the details for the interconnection requirements to enable the Seller to design, purchase, construction and commissioning of the Interconnection Facilities in the Purchaser's systems.

7.4 Connection to the Purchaser's System

The Seller shall liaise with the Purchaser for the connection of the Plant to the Purchaser System at the Delivery Point.

7.4.1 Information

The Seller shall keep the Purchaser informed of the progress of the design, financing, supply, construction and installation of the Interconnection Facilities and equipment to be installed by it, and every month shall provide a progress report in respect thereof.

7.4.2 Monitor Progress

The Seller shall: -

- 7.4.2.1 Ensure that the Purchaser and any representatives appointed by the Purchaser, are afforded reasonable access to the Site upon giving the Seller reasonable notice provided that such access does not materially interfere with the construction works or expose any person on the Site to any danger;

- 7.4.2.2 Make available for inspection at the Site copies of all plans and designs, other than any proprietary information of the Seller or any sub-contractor, in relation to the construction, or any part thereof; and
- 7.4.2.3 Within three (3) months of the Plant commissioning date, supply the Purchaser with one (1) set of reproducible copies and two (2) sets of white print copies or equivalent of all "as built" plans and designs relating to the operation or maintenance of the Interconnection Facilities as the Purchaser may reasonably require. The Seller shall also provide to the Purchaser two (2) copies of the operation and maintenance manuals in respect of the Interconnection Facilities.

7.4.3 Disclaimer

The Seller: -

- 7.4.3.1 Accepts that any information provided by the Seller or any engineering review or inspection conducted by the Purchaser is solely for the Purchaser's own information and accordingly, the Purchaser's review or failure to review or carry out any inspection shall not be construed as constituting any approval or acceptance of Interconnection Facilities or the Plant, and the Purchaser makes no representation as to the engineering soundness of the Interconnection Facilities or the Plant nor shall it be treated as having accepted Interconnection Facilities or the Plant as fit to meet the terms of this Agreement.
- 7.4.3.2 Shall in no way represent to any third party that the Purchaser is responsible for the engineering soundness of the plant as a result of any review or inspection done by the Purchaser.
- 7.4.3.3 Shall, subject to the other provisions of this Agreement, be solely responsible for the economic and financial feasibility, operational capacity and reliability of the Plant.

7.5 Testing of Interconnection Facilities

In addition to the respective obligations set out under this Clause **Error! Reference source not found.**, the Parties shall use all reasonable endeavours to cooperate in testing the Interconnection Facilities in accordance with **Error! Reference source not found.** and the schedule developed by the Operating Committee and at such other times thereafter as either Party may reasonably require.

7.6 Maintenance Schedule

The Purchaser shall use its reasonable endeavours to coordinate its maintenance program for the Interconnection Facilities with the approved Scheduled Outages so as to minimize any disruption to the operation of the Plant.

8. METERING AND TELECOMMUNICATIONS

8.1 Installation and Ownership of Metering Equipment [and SCADA System]

8.1.1 The Seller, at its own expense, shall install, procure, operate, and maintain the Metering System and a SCADA System for remote recording of Plant Output Profile in accordance with Schedule 4 -, and that is compatible with that of the Purchaser.

8.1.2 The Purchaser, at its own expense shall design, finance, construct, install, own, operate and maintain meters and metering devices for backup purposes pursuant to Schedule 4 - ("**Backup Metering System**") and a SCADA System for remote recording of Plant Output Profile in addition to the Metering System and SCADA System for remote recording of Plant Output Profile maintained by the Seller .

8.2 Testing and Inspection of Metering System

8.2.1 The Seller shall inspect and test at its own expense the Metering System and the associated SCADA System and the Purchaser shall inspect and test at its own expense the Backup Metering System and the associated SCADA System for accuracy in accordance with Schedule 4 - by the date required for the completion of the Interconnection Facilities under Clause 7.1.46.2, and thereafter at intervals of not less than hundred and eighty (180) Days.

8.2.2 With respect to each testing of the Metering System and the associated SCADA System, the Seller shall give the Purchaser no less than forty eight (48) hours advance notice of during Business Days of such testing, and the Purchaser shall have a representative present during any such testing, as well as during any inspection of the Metering System and the associated SCADA System or adjustment thereof (but the test, inspection or adjustment may be taken if the Purchaser has no representative present if the Purchaser was informed in accordance with this Clause).

8.2.3 With respect to each testing of the Backup Metering System and the associated SCADA System, the Purchaser shall give the Seller no less than twenty four (24) hours advance notice during Business Days of such testing, and the Seller shall have a representative present during any such testing, as well as during any inspection of the Backup Metering System and the associated SCADA System] or adjustment thereof (but the test, inspection or adjustment may be taken if the Seller has no representative present if the Seller was informed in accordance with this Clause).

8.3 Measurement [and verification] of Net Energy Output and Dependable Capacity

8.3.1 The Seller shall record the monthly Plant Output Profile at the Plant using the SCADA System associated with the Metering System and the Purchaser shall record the monthly Plant Output Profile at the Control

- Centre using the SCADA System associated with the Backup Metering System.
- 8.3.2 Both the Seller and Purchaser shall maintain a record of monthly Plant Output Profiles.
- 8.3.3 Net Energy Output or Dependable Capacity shall be determined using the Plant Output Profile recorded by the Seller.
- 8.3.4 The Seller shall read the Metering System Monthly on the Last Business Day of each Month (or such other Day as may be agreed upon by the Operating Committee) for the purpose of [verifying]/[measuring] the Net Energy Output or Dependable Capacity and the Purchaser shall give the Seller not less than three (3) Business Days' notice of its intention to read the Metering System.
- 8.3.5 The Purchaser shall have the right to have a representative present during any such reading (but the reading may be taken if the Seller has no representative present). The Seller shall take and record such reading together with a photographic record thereof, and the Purchaser shall maintain a log of all such meter readings. In the event that the Metering System is not in service as a result of maintenance, repairs or testing, then the Backup Metering System shall be used during the period that the Metering System is not in service and the foregoing provisions of this Clause 8.3.5 shall apply to the reading of the Backup Metering System.
- 8.3.6 When, as a result of any test pursuant to Clause 8.2, the Metering System is found to be inaccurate by more than one half of one percent (0.5%) or is otherwise improperly functioning, then the correct amount of Net Energy Output and Dependable Capacity delivered to the Purchaser for the actual period during which inaccurate measurements were made, if any, shall be determined as follows:
- 8.3.6.1 first, the readings of the Backup Metering System, if any, shall be utilized to calculate the correct amount of Net Energy Output and Dependable Capacity, unless a test of such Backup Metering System, as required by either Party, reveals that the Backup Metering System is inaccurate by more than one half of one percent (0.5%) or is otherwise improperly functioning;
- 8.3.6.2 if the Backup Metering System is not within the acceptable limits of accuracy or is otherwise improperly functioning, then [the Net Energy Output calculated and the Dependable Capacity determined using the monthly Plant Output Profile shall be considered final provided that the Plant Output Profile recorded by the Seller matches with the Plant Output Profile recorded by the Purchaser;
- 8.3.6.3 if the two Plant Output Profiles do not match necessary corrections to the Plant Output Profiles will be carried out

jointly by the Seller and the Purchaser using Dispatch instructions issued during the concerned month.)/(the Seller and the Purchaser shall jointly prepare an estimate of the correct reading on the basis of all available information including deliveries of Net Energy Output during periods of similar operating conditions when the Metering System was registering accurately;

8.3.6.4 in the event that the Parties cannot agree on the actual period during which inaccurate measurements were made, the period during which measurements are to be adjusted shall be the shorter of (i) one-half of the period from the last previous test of the Metering System, or (ii) [] Days immediately preceding the test which found the Metering System to be inaccurate; and

8.3.6.5 the difference between the previous payments by the Purchaser for the period of inaccuracy or improper functioning and the recalculated amount shall be offset against or added to the next payment to the Seller under this Agreement, as appropriate.

In the event that the Purchaser and the Seller fail to agree upon any estimate pursuant to this Clause 8.3.6, then the matter may be referred by either Party for determination by an expert pursuant to Clause 21.2.

8.4 Sealing, Repair and Replacement of Meters

8.4.1 The Metering System and the Backup Metering System shall comply with Schedule 4 -and shall be jointly sealed. Such seals shall be broken only by the Purchaser's personnel in the presence of personnel from the Seller when the Metering System or the Backup Metering System is to be inspected, tested or adjusted (save that either Party's personnel was informed in accordance with Clause 8.2.2 or Clause 8.2.3 but was not present at the scheduled time, in which case the Party being present may break the seal).

8.4.2 When any component of the Metering System is found to be outside acceptable limits of accuracy or otherwise not functioning properly, the Seller shall forthwith repair, recalibrate or replace such component of the Metering System. Similarly, when any component of the Backup Metering System is found to be outside acceptable limits of accuracy or otherwise not functioning properly, the Purchaser shall forthwith repair, recalibrate or replace such component of the Backup Metering System. Upon the completion of any examination, maintenance, repair or recalibration of, or replacement of any component in, the Metering System or the Backup Metering System, the relevant metering system shall be jointly sealed.

8.5 Telecommunications Equipment

The Seller shall provide at its sole cost and expense the telecommunications equipment specified in Schedule 4 -. The selection and installation of items to be provided by the Seller in accordance with this Clause 8.5 shall be subject to the prior written approval of the Purchaser.

9. OPERATION AND MAINTENANCE OF THE PLANT

9.1 Operation and Maintenance of the Complex

9.1.1 The Seller shall operate and maintain the Complex in accordance with the terms of this Agreement, the operating procedures developed in accordance with Clause 4.5, the Laws of Tanzania, the Grid Code, and the Seller Consents, Prudent Utility Practices, and Prudent Electrical Utility Practices; provided, however, that the Seller may contract with the O&M Contractor to operate and maintain the Complex; provided, further, that the appointment of the O&M Contractor by the Seller shall not relieve the Seller of any of its obligations or potential liability regarding the insuring, operation or maintenance of the Complex or any liability whatsoever resulting from a breach of any term or condition of this Agreement.

9.1.2 The Complex will be operated within the range of voltage levels specified in Schedule 5 -. Subject to Technical Limits, the Seller shall operate and maintain the Complex in a manner that will not have adverse effects on the Power Purchaser's voltage level or voltage.

9.1.3 Within thirty (30) day following the Commercial Operations Date, the Seller shall notify the Power Purchaser, of its projection estimated in good faith for Net Electrical Output on monthly basis (or any part Months as the case may be) for the remainder of the year, or, if the Commercial Operations Date occurs within one hundred and eight (180) Days of the end of a year, for the remainder of that year and the following year.

9.1.4 Not later than the first (1st) Day of the Month following the Commercial Operation Date and not later than the 1st Day of such Month of each year thereafter the Seller shall notify the Power Purchaser the projections, estimated in good faith for Net Electrical Output on a daily basis for the following three (3) Months, or, if the Commercial Operations Date occurs within fourteen (14) Days of the end of a Month, its projections for the remainder of the Month and for the following three (3) Months, as the case may be.

9.2 Forecasting of Net Delivered Energy

9.2.1 In view of the intermittency inherent in resource and therefore the generating capability of the Complex, the Parties agree that meticulous adherence to the provisions of the Grid Code relating to the scheduling and dispatch of generation facilities connected to the Grid System is not possible in the case of the Complex.

9.2.2 Notwithstanding Clause 9.2.1, the Seller acknowledges that accuracy in forecasting the Net Delivered Energy is material for the quality and reliability of electricity supplies across the Grid System. The Seller accordingly agrees that it shall use state-of-the-art best possible means available to predict the long-term and short-term availability of the Complex at the Site and on that basis shall provide to the Purchaser:

- (i) not later than thirty (30) Days before the beginning of each Agreement Year, a year-ahead forecast of Net Delivered Energy on a Monthly basis for the succeeding Agreement Year; and
- (ii) not later than one (1) Week before the beginning of each Month, a month-ahead forecast of Net Delivered Energy on a Weekly basis for the succeeding Month.
- (iii) The forecasts of Net Delivered Energy provided by the Seller to the Purchaser under Clause 9.2.2 shall not be binding on the Seller or the Purchaser.

9.3 Operation by the Seller

9.3.1 The Seller shall control and operate the Plant in accordance with the practice applied by a Reasonable and Prudent Operator.

9.3.2 Subject to the Minimum Functional Specifications, the Seller shall operate and maintain the Plant in such a manner so as not to have an adverse effect on the Purchaser's voltage level, voltage waveform or the Purchaser's Grid System.

9.4 Availability

9.4.1 The Seller shall be responsible for the mechanical and electrical availability of the Complex and its components for the generation of Net Delivered Energy throughout the Term. The Seller shall ensure the availability of the Complex at any time for generation and delivery of Net Delivered Energy (as determined on the basis of functional and technical specifications in Schedules 2 and 5), the Complex generates and delivers the Net Delivered Energy at the Interconnection Point, except when and to the extent that generation and delivery of Net Delivered Energy is prevented partially or completely during the continuance of or on account of a Force Majeure Event, Scheduled Outage or Maintenance Outage.

9.4.2 At any time that the Seller enables generation and delivery of Net Delivered Energy (as determined on the basis of functional and technical specifications in **Error! Reference source not found.** and **Error! Reference source not found.**), which, however, the Complex is partially or wholly unable to generate and deliver for reasons attributable to the Seller (including mechanical or electrical non-availability of the Complex or any component thereof), such partial or complete non-availability of the

Complex shall not constitute a Non-Project Event and the Net Delivered Energy not generated as a consequence shall be excluded in the computation of Non-Project Missed Volume.

9.5 **Scheduled Outages**

- 9.5.1 At least forty-five (45) Days prior to the Scheduled Commercial Operations Date, the Seller shall submit to the Purchaser its desired schedule of Scheduled Outage periods for the remainder of the first Operating Year.
- 9.5.2 For each subsequent Operating Year, the Seller shall submit to the Purchaser its desired schedule of Scheduled Outage periods for the following Operating Year no later than [] Days prior to the beginning of such Operating Year [DATE].
- 9.5.3 The Purchaser shall notify the Seller within fourteen (14) Days following the receipt of the schedule for the Scheduled Outage periods in writing whether the requested Scheduled Outage periods are acceptable.
- 9.5.4 If the Purchaser cannot accept any of the requested Scheduled Outage periods, the Purchaser shall advise the Seller when the unacceptable Scheduled Outage period can be rescheduled. Such rescheduled period shall be as close as reasonably practicable to the requested period, shall comply with the Minimum Functional Specifications, and shall be of equal duration as the requested period.
- 9.5.5 The Seller shall conduct Scheduled Outages only during periods agreed to in writing by the Purchaser as aforesaid.
- 9.5.6 Under no circumstances shall the Seller be permitted to schedule Scheduled Outages during the Peak Months specified in Schedule 1 -. The Purchaser may designate new Peak Months by giving notice to the Seller at least three (3) Months prior to the next Day by which the Seller must submit its proposed schedule of Scheduled Outage periods pursuant to Clause 9.5.4; provided, however, that the Purchaser may not designate more than three (3) Months each calendar Year as Peak Months; and provided further, that the Purchaser may not designate more than three (3) consecutive Months as Peak Months without the prior consent of the Seller.
- 9.5.7 Under no circumstances shall the Seller be permitted to schedule Scheduled Outages for more than one Unit at any given time; provided, however, that the Seller may schedule a Scheduled Outage for the entire Plant at one time for up to twelve (12) hours per Operating Year subject to the Minimum Functional Specifications and the prior approval of the Operating Committee. Commencing with the Commercial Operations

Date, the Seller may not schedule more than a total of [] Plant Hours of Scheduled Outages during any Operating Year.

- 9.5.8 The Purchaser may, upon seven (7) Days prior written notice, require the Seller to reschedule a Scheduled Outage; provided, however, that the Purchaser shall not request that such Scheduled Outage be rescheduled in a manner or time outside the Minimum Functional Specifications.

9.6 Maintenance Outages

When the circumstances warrant a Maintenance Outage, the Seller may advise the Purchaser of such circumstances and of the planned commencement and estimated duration of the Maintenance Outage. The Purchaser shall, if reasonably necessary grant the Seller the right to conduct such Maintenance Outage at a time reasonably acceptable to the Purchaser.

9.7 Emergencies

- 9.7.1 The Purchaser and the Seller shall jointly establish plans for operating the Plant during an Emergency. Such plans shall include recovery from a local or widespread electrical blackout and voltage reduction in order to effect load curtailment. The Seller shall, within the Minimum Functional Specifications, comply with such Emergency procedures. Upon the Purchaser's request, the Seller shall make technical references available to the Purchaser concerning Start-Up times, black-start capabilities, and minimum load-carrying ability.

- 9.7.2 During an Emergency and if requested in Dispatch instructions from the Purchaser, the Seller shall supply such power as the Plant thereafter is able to generate within the Minimum Functional Specifications. If the Plant has a Scheduled Outage or a Maintenance Outage and such Scheduled Outage or Maintenance Outage occurs or would occur coincident with an Emergency, the Seller shall use its reasonable efforts to reschedule the Scheduled Outage or Maintenance Outage or, if the Scheduled Outage or Maintenance Outage has begun, to expedite the completion of the work to restore power supply as soon as possible.

9.8 Fuel Supply

Throughout the Term, the Seller shall:

- 9.8.1 maintain facilities necessary to feed geothermal supply to the Plant in order to operate the Plant at the Dependable Capacity; and
- 9.8.2 on or before the Scheduled Commercial Operation Date and from time to time thereafter, provide to the Purchaser for its prior written approval, the Fuel Supply Agreement, fuel transportation agreement, backup fuel agreement and other commitments for the supply and transportation of Fuel and backup fuel (if applicable), and any [material] amendments to any of these documents.

9.9 Employment of Qualified Personnel and Procurement of Local Services and Supplies

- 9.9.1 The Seller shall employ personnel (management, supervisory and otherwise and shall ensure that all Contractors employ citizens of Tanzania for the construction, installation, operation, maintenance and management of the project to the maximum extent reasonable, taking into consideration availability and the required skills.
- 9.9.2 From the Commercial Operations Date, the Seller shall ensure that personnel are on duty at the Plant at all times, 24 hours a Day and seven Days a Week.
- 9.9.3 The Seller shall use reasonable endeavours to employ local labour in both skilled and unskilled capacities and shall ensure that they undergo continuous training.
- 9.9.4 The Seller shall use reasonable endeavours to procure local materials, services, and supplies.
- 9.9.5 The Seller and any Contractor shall include employee training programmes as required in the normal conduct of its business, which training programmes shall from time to time include training in each of the skills used in the planning, design, construction, operation and maintenance of the Project and training in management for those employees qualified for management training.
- 9.9.6 The Seller shall train persons at management and supervisory level, at a minimum, up to seventy percent (70%) of qualified local persons in the management and operation of the Plant and up to seventy percent (70%) of qualified local persons in the maintenance of the Plant.

9.10 Operating Committee Membership and Duties

- 9.10.1 On or before six (6) Months prior to the Scheduled Commercial Operations Date, the Parties shall establish an Operating Committee comprising six (6) members. Each Party shall designate half (0.5) members to represent it on the Operating Committee, and either Party may remove or replace any of its Operating Committee members at any time upon notice to the other Party. The Operating Committee shall be responsible for assisting the Parties in finalising the Operating Procedures in accordance with Clause 4.5 and for advising the Parties in relation to matters herein. The Operating Committee shall develop procedures for the holding of meetings, the keeping of minutes of meetings, and the appointment and operation of sub-committees. The chairmanship of the Operating Committee shall rotate each six Months between the Parties and the Parties agree that the first Chairman shall be nominated by the Purchaser. The Secretary shall be appointed by the other Party not chairing the committee during that period. Decisions of the Operating Committee

shall require the approval of a majority of the members of the Operating Committee.

9.10.2 The Operating Committee shall be responsible for:

9.10.2.1 developing the operating procedures pursuant to Clause 4.5 (and any subsequent revisions thereto);

9.10.2.2 approving procedures for the Commissioning of the Plant pursuant to Clause 9.13.2 and Schedule 3 -;

9.10.2.3 establishing other procedures relating to the interaction of the Plant, the Metering System, the Interconnection Facilities and the Purchaser Grid System; and

9.10.2.4 where appropriate, for proposing solutions to other issues and attempting to resolve Disputes concerning the testing, operation, and maintenance of the Plant, including (but not limited to):

- (a) the coordination of the respective programs and procedures of the Parties for the construction, commissioning and operation of the Interconnection Facilities, the Metering System and the Plant, and agreement where necessary upon the respective Commissioning procedures;
- (b) the discussion of the steps to be taken on the occurrence of any Force Majeure, or the shutdown or reduction in capacity for any other reason of the Interconnection Facilities or the Plant;
- (c) the coordination of Scheduled Outages;
- (d) safety matters affecting the Plant, the Parties or their Contractors;
- (e) clarification of Emergency plans developed pursuant to Clause 9.7 for recovery from a local or widespread electrical blackout;
- (f) review and revision, subject to the Purchaser approval, of protection schemes; and
- (g) any other matter mutually agreed to by the Parties.

9.10.3 The Parties shall instruct their representatives on the Operating Committee to act in good faith in dealing with matters considered by the Operating Committee. The Parties shall consider and use reasonable efforts to

incorporate decisions of the Operating Committee in the operation and maintenance of the Plant and the Interconnection Facilities.

- 9.10.4 The Operating Committee on its own shall not (a) override or waive any provisions of this Agreement; or (b) amend or modify any provisions of this Agreement and no actions of any of the members of the Operating Committee shall be deemed to be a waiver amendment or modification.
- 9.10.5 For the avoidance of doubt the Seller shall own, operate and maintain the Plant in accordance with (Clauses 6.89) and any actions or omissions by the Operating Committee shall be attributable to the Seller as if the Operating Committee is acting in the Seller's interest and on behalf of the Seller.

9.11 Inspections and Records

- 9.11.1 The Purchaser shall have the right to visit and observe the Plant and/or the operation thereof upon reasonable advance notice to the Seller. Such visits and observation shall not be construed as an endorsement by the Purchaser of the design of the Plant nor as a warranty by the Purchaser of the safety, durability or reliability thereof.
- 9.11.2 Each Party shall keep complete and accurate records and all other data required by each of them for the purposes of proper administration of this Agreement. Among other records and data, the Seller shall maintain an accurate and up-to-date operating log in a format reasonably acceptable to the Purchaser which log shall include records of:
 - 9.11.2.1 Active Power and Reactive Power production for each clock [hour/half-hour], frequency and [□] kV bus voltage at all times;
 - 9.11.2.2 changes in operating status, Scheduled Outages, Maintenance Outages and Forced Outages;
 - 9.11.2.3 any unusual conditions found during inspections; and
 - 9.11.2.4 other matters agreed to by the Operating Committee.
- 9.11.3 Either Party shall have the right, upon reasonable prior written notice to the other Party, to examine and/or make copies of the records and data of the other Party relating to this Agreement at any time during normal office hours during the period such records and data are required to be maintained.
- 9.11.4 All records and data referred to in Clause 9.11.3 shall be maintained for a minimum of eighty-four (84) Months after the creation of such record or data and for any additional length of time required by regulatory agencies with jurisdiction over the Parties. Upon expiration of such eighty-four (84) Month period, neither Party shall dispose of or destroy any such records without sixty (60) Days prior written notice (generally describing

the records or data to be destroyed or disposed of) to the other Party, and the Party receiving such notice may receive such records in lieu of such disposal or destruction by giving the notifying Party notice fourteen (14) Days prior to the expiration of the sixty (60) Day period.

9.11.5 Either Party shall have the right, upon ten (10) Days prior written notice to the other Party, to examine the records and data kept by the other Party pursuant to Clause 9.11.2 at any time during normal office hours during the period such records and data are required hereunder to be maintained. For the avoidance of doubt, it is agreed that references to records and data in Clause 9.11.2 includes records and data created, recorded, maintained and retrieved in electronic form.

9.11.6

9.12 Periodic Reports

9.12.1 The Seller shall, as soon as available but in any event within ninety (90) Days after the end of each Financial Year, furnish to the Purchaser:

9.12.1.1 five (5) copies of its complete financial statement for such Financial Year (which are in agreement with its books of accounts and prepared in accordance with accounting principles which are generally accepted in Tanzania and consistently applied), together with an audited report thereon, all in accordance with the requirements of Cap. 212 of the Laws of Tanzania;

9.12.1.2 a copy of any management letter or other communication sent by the auditors to the Seller or to its management in relation to the Seller's financial, accounting and other systems, management and accounts; and

9.12.1.3 a report by the auditors certifying that, based on its said financial statements, the Seller was in compliance with its financial obligations under the Loan Documents as of the end of the relevant Financial Year or, as the case may be, detailing any non-compliance. In addition, the Seller shall authorize its auditors (whose fees and expenses shall be for the account of the Seller) to communicate directly with the Purchaser at any time regarding the Seller's accounts and operations and shall furnish to the Purchaser a copy of such authorization.

9.12.2 the Seller shall, as soon as available but in any event within thirty (30) Days after the end of each one (1) Month period of each Financial Year, furnish to the Purchaser:

9.12.2.1 five (5) copies of the Seller's complete financial statements for such one (1) Month period, all in accordance with accounting principles which are generally accepted in Tanzania and

consistently applied, and, if requested by the Purchaser, certified by an officer of the Seller; and

- 9.12.2.2 a report on any factors materially and adversely affecting or which might materially and adversely affect the Seller's business and operations or its financial condition (including but not limited to any information related to parent companies, subsidiaries, sponsors and shareholders).

9.13 **Environmental Protection and Safety**

9.13.1 The Seller shall in accordance with the Laws of Tanzania and acting as a Reasonable and Prudent Operator, take necessary and adequate steps to:

9.13.1.1 comply with all Environmental Regulations to which it or the Plant is subject; and

9.13.1.2 take measures necessary to remediate or otherwise correct any breach of Environmental Regulations required to be remediated or otherwise corrected under the Laws of Tanzania,

in each case, as caused by the Seller or any of its Contractors, agents, or employees in relation to the Project or any act or activity related thereto.

9.13.2 The Seller shall promptly (but in no event more than ten (10) Business Days after such an accident or emergency) notify the relevant Government Authority of any environmental accidents or emergencies and shall report to the Purchaser periodically, but in no event no less frequently than monthly following an environmental accident or emergency, on remediation programmes and emergency response plans related to the operations of the Plant until the impact of the accident or emergency has been properly remediated in accordance with the Laws of Tanzania..

9.14 **Lenders' step-in right**

9.14.1 The Lenders, as owner of the Project, or as collateral assignee of this Agreement, shall be entitled to exercise, in the place and stead of the Seller, any and all rights and remedies of the Seller under this Agreement in accordance with the terms of this Agreement. The Lenders shall also be entitled to exercise all rights and remedies of owners or secured parties, respectively, generally with respect to this Agreement and the Project.

9.14.2 The Lenders shall have the right, but not the obligation, to pay all sums due under this Agreement and to perform any other act, duty or obligation required of the Seller thereunder or cause to be cured any default of the Seller thereunder in the time and manner provided by the terms of this Agreement. Nothing herein requires the Lenders to cure any default of the Seller under this Agreement or (unless the Lenders have succeeded to the Seller's interests under this Agreement) to perform any act, duty or

obligation of the Seller under this Agreement, but the Purchaser hereby gives it the option to do so.

- 9.14.3 Upon the exercise of remedies, including any sale of the Project by the Lenders, whether by judicial proceeding or under any power of sale contained therein, or any conveyance from Seller to the Lenders (or any assignee of the Lenders as defined below) in lieu thereof, the Lenders shall give notice to the Purchaser of the transferee or assignee of this Agreement. Any such exercise of remedies shall not constitute a default under this Agreement.
- 9.14.4 Upon any rejection or other termination of this Agreement pursuant to any process undertaken with respect to the Seller under the Bankruptcy Act, Cap. 25 of the Laws of Tanzania, at the request of Lenders made within ninety (90) days of such termination or rejection, Purchaser upon satisfaction of the assignee's competence, shall enter into a new agreement with Lenders or its assignee having substantially the same terms and conditions as this Agreement. The new Agreement shall be submitted to the Authority for approval.
- 9.14.5 If the Lenders or its assignee (including any purchaser or transferee), pursuant to an exercise of remedies by the Lenders, shall acquire title to or control of Seller's assets and shall, within the time periods described in Clause 9.14.4 above, cure all defaults under this Agreement existing as of the date of such change in title or control in the manner required by this Agreement and which are capable of cure by a third person or entity, then such person shall no longer be in default under this Agreement, and this Agreement shall continue in full force and effect.

10. TESTING AND CAPACITY RATINGS

10.1 Testing and Commissioning

- 10.1.1 The Seller shall carry out testing and commissioning of the Plant, testing the Dependable Capacity of the Plant at the Commercial Operations Date and testing of Dependable Capacity of the Plant thereafter in accordance with this Clause 10.1.1 and Schedule 3 -.
- 10.1.2 If Two Step Operation of the Plant is agreed in the Minimum Functional Specifications of Schedule 1, Commissioning of the Combined Cycle Operation shall be completed within [two] years of the Commercial Operation Date.
- 10.1.3 The Purchaser shall be given prior written notice of any testing or Commissioning procedure in accordance with Schedule 3 - and shall be entitled to have representatives present for the purpose of observing any such procedure (but such testing or Commissioning may be performed if the Purchaser has no representative present). The Purchaser shall use its

reasonable efforts to comply promptly with all reasonable requests by the Seller for assistance in carrying out such testing and Commissioning.

- 10.1.4 If Commissioning of the Plant [or Two Step Operation] indicates that there will be a Commissioned Shortfall, the Seller may request one additional test of Dependable Capacity to be conducted at the Seller's expense in accordance with Schedule 3 - within thirty (30) Days after the Plant has been Commissioned. If no such additional test is requested by the Seller, the Commissioned Dependable Capacity shall be set in accordance with the test carried out pursuant to Clause 10.1.1. If such additional test is requested, then the Commercial Operations Date shall be delayed until such additional test is complete, and the Commissioned Dependable Capacity shall be set in accordance with the additional test.
- 10.1.5 If any test after the Commercial Operations Date[or Commissioning of Two Step Operation]indicates that the Dependable Capacity has fallen by [□ %] percent below the Commissioned Dependable Capacity, the Seller may request one additional test of Dependable Capacity to be conducted within six (6)Days at the Seller's expense in accordance with Schedule 3 - .
- 10.1.6 Capacity Payments and liquidated damages provided in Clause 12.3.3 will be based at all times on the most recent completed test of Dependable Capacity.
- 10.1.7 Once the Seller is satisfied that all the requirements in the **Error! Reference source not found.** have been fulfilled, the Seller shall notify the Purchaser that not less than 5 Days in advance (or such lesser period as the Parties may agree), the Seller's intention to declare that the Solar Power Plant has reached the Commercial Operation Date. The Purchaser shall accept such notice in writing and cause the required Meter reading(s) to be taken on the Commercial Operation Date.

10.2 Test Results

The Seller shall provide the Purchaser with copies of the results of all tests performed pursuant to Schedule 3 - .

10.3 Nomination of Dependable Capacity

Upon completion of testing pursuant to Clause 10.1 and Schedule 3 -, the Seller shall notify the Purchaser in writing as to the amount of Dependable Capacity available from the Plant.

10.4 Disputes

In the event that the Purchaser contests the outcome of the testing of Dependable Capacity by the Seller in accordance with Clause 10 or the protection tests described in Schedule 3 - , it shall notify the Seller in writing within forty-five (45) Business Days and the matter shall be resolved by referral to an expert pursuant to Clause 21.2.

11. SALE AND PURCHASE OF ENERGY AND CAPACITY

11.1 Purchase of Dependable Capacity and Net Energy Output

Subject to and in accordance with the terms of this Agreement, from and after the Commercial Operations Date the Seller shall make available and sell to the Purchaser, and the Purchaser shall purchase from the Seller for the consideration described in Clause 11.3, the Dependable Capacity and Net Energy Output of the Plant.

11.2 Ancillary Services

The Seller shall provide Ancillary Services to the Purchaser, and the costs for the provision of the Ancillary Services shall be for the account of the Seller.

11.3 Purchaser's Exclusive Right to Energy and Capacity

Except to the extent that electric energy is required for the operation of any part of the Complex, the Seller shall not, without the prior written approval of the Purchaser:

- 11.3.1 deliver electric energy produced at the Complex to any Person other than the Purchaser; or
- 11.3.2 confer upon any Person other than the Purchaser any right in or to the Net Electrical Output or the Tested Dependable Capacity.

12. COMPENSATION, PAYMENT AND BILLING

12.1 Capacity Payment

- 12.1.1 Beginning on the first day of the Operation Period, the Purchaser shall pay to the Seller each Month, in arrears on the thirtieth (30th) Business Day of each Month, an amount equal to the Capacity Payment in accordance with Clause 12.8.
- 12.1.2 Notwithstanding Clause 12.1.1 above, the Purchaser may withhold all such payments if any of the test results specified in Clause 10.2 have not been delivered pursuant thereto or if the Purchaser has notified the Seller that it contests the outcome of a test in accordance with Clause 10.4, pending resolution of the matter.
- 12.1.3 The amount of the Capacity Charge shall be as set forth in Annex G of Schedule 5.
- 12.1.4 If two step operation is agreed in the Minimum Functional Specifications in Schedule 1 -:
 - (i) Capacity Charge declared, by the Seller, for Open Cycle Operation in Annex G of Schedule 5 - will be considered for

calculation of the Capacity Payment during the period of Open Cycle operation.

- (ii) Capacity Charge declared, by the Seller, for Combined Cycle Operation in Annex G of Schedule 5 - will be considered for calculation of the Capacity Payment during the Combined Cycle Operation. If Combined Cycle Operation is declared by the Seller on a date which is not the first date of the Month Capacity Charge applicable for Open Cycle Operation will apply from the first day of that month until the day Combined Cycle Operation is declared and Capacity Charge applicable for Combined Cycle Operation from the date of declaring Combined Cycle Operation until the last day of that month.

12.2 Energy Payment

12.2.1 After the Commercial Operations Date, in accordance with Clause 12.8, the Purchaser shall pay to the Seller, in arrears on the forty five (45th) Business Day of each Month, the Energy Charge for each kWh of Net Energy Output delivered from the Plant to the Purchaser during the preceding Month (each Monthly payment, an "**Energy Payment**").

12.2.2 The amount of the Energy Charge shall be as set forth in Schedule 5-.

12.3 Supplemental Charges

12.3.1 Delays in Commissioning

12.3.1.1 If the Plant has not been commissioned on or before the Required Commercial Operations Date, the Seller shall pay to the Purchaser [] per Month of the Contract Capacity (prorated daily) for each Day by which the Plant is delayed beyond its Required Commercial Operations Date.

12.3.1.2 [Notwithstanding the contents of Clause 12.3.1.1 above, the cumulative amount of such payment shall not exceed [].]

12.3.1.3 Payments made in accordance with Clause 12.3.1.1 above, shall be liquidated damages for the detrimental impact of such delay upon the Purchaser's generation planning.

12.3.2 Shortfalls in Commissioned Dependable Capacity

12.3.2.1 If there is a Commissioned Shortfall, then the Seller shall pay to the Purchaser as liquidated damages for the detrimental impact upon the Purchaser's generation planning five hundred Dollars (US\$ 500) per kW of such Commissioned Shortfall.

12.3.2.2 Notwithstanding the contents of Clause 12.3.2.1 above, the amount of such payment shall not exceed [].

12.3.3 On-Going Dependable Capacity Shortfalls

- 12.3.3.1 If after the Commercial Operations Date, there is an On-Going Dependable Capacity Shortfall, then the Seller shall pay to the Purchaser, as liquidated damages, six hundred and twenty-five Dollars (US\$ 625) for each kW per Month of such On-Going Dependable Capacity Shortfall until the next testing of Dependable Capacity which may be requested by the Seller pursuant to Clause 9.13.2 and Schedule 3 -.
- 12.3.3.2 Notwithstanding the contents of Clause 12.3.3.1 above, the amount of such payment shall not exceed [in any Operating Year]/[during the Term].

12.3.4 Dispatch Levels

- 12.3.4.1 From and after the Commercial Operations Date, in the event that after identical Dispatch requests separated by a sufficient period of time for the Seller to have complied with the first request based on ramp time schedules as provided in **Annex B** of Schedule 1, the Seller does not achieve the operating level requested by the Purchaser pursuant to Clause 9.1 within the time allowed by Schedule 1, within a tolerance of plus or minus percent, then the Seller shall pay to the Purchaser, as liquidated damages per kWh for each kWh outside the tolerance.
- 12.3.4.2 Notwithstanding the contents of Clause 12.3.4.1 above, the Purchaser shall not be entitled to liquidated damages pursuant to Clause 12.3.4.1 above, if the requested operating level cannot be achieved within the Minimum Functional Specifications or is above the Declared Available Capacity of the Plant (as adjusted by Forced Outages declared subsequent to such Dispatch requests).

12.3.5 Adjustment

The amounts of all of the liquidated damages set forth in Clause 12.3 shall be adjusted from time to time in accordance with Schedule 5 -.]

Schedule 5 may be drafted to include a mechanism for adjusting liquidated damages.

12.3.6 **Waiver of Defences**

12.3.6.1 The Parties agree that:

- (a) the Purchaser may be substantially damaged in amounts that may be difficult or impossible to determine in the event that the Plant or any part thereof:
 - (i) is not in service by the dates required;
 - (ii) is not capable of achieving and maintaining the expected Dependable Capacity; or
 - (iii) cannot achieve the designated operating levels; and
- (b) the Seller may be substantially damaged in amounts that may be difficult or impossible to determine in the event that the Purchaser delays access to the existing infrastructure for the Interconnection Facilities by the date required,

and the Parties have therefore, to the limited extent set out in this Agreement, agreed on sums that the Parties agree are reasonable as liquidated damages.

12.3.6.2 The Parties further agree that the payment of liquidated damages is in lieu of actual damages in respect of the circumstances described in Clauses 12.3.6.1(a) and 12.3.6.1(b) above, and that the payment of liquidated damages under Clauses **Error! Reference source not found.** and 12.3.1 to 12.3.4 (inclusive) shall be the exclusive remedy of the Purchaser or the Seller, as appropriate, for such occurrences, unless and until:

- (a) the Seller has committed a Seller Event of Default within the meaning of Clause 21.1.4 in the case of liquidated damages payable to the Purchaser; and
- (b) the Purchaser has committed a Purchaser Event of Default within the meaning of Clause 20.2.2 in the case of liquidated damages payable to the Seller.

12.3.6.3 The Seller and the Purchaser hereby waive any defences as to the validity of any liquidated damages in this Agreement on the grounds that such liquidated damages are void as penalties.

12.4 **Deemed Energy**

12.4.1 In the event of Deemed Energy the Purchaser shall pay the Seller the Deemed Energy Payment for the Deemed Energy in accordance with this Agreement.

12.4.2 Notwithstanding any delay or failure by the Purchaser to notify the Seller in accordance with this Clause, for avoidance of doubt, the Purchaser shall pay the Seller the Deemed Energy Payment for the Deemed Energy in accordance with this Agreement.

12.5 Security

12.5.1 Construction Security

12.5.1.1 On or before Financial Closing, the Seller shall provide to the Purchaser security ("**Construction Security**") in the amount of [□]. The Construction Security shall be an unconditional and irrevocable direct pay letter of credit issued by a bank acceptable to the Purchaser in form and substance satisfactory to the Purchaser. The Construction Security may be applied to the payment of liquidated damages or other Damages and accrued interest thereon as set forth in Clause 12.6.

12.5.1.2 There shall be no discontinuity between the expiration of the Construction Security and the effectiveness of the Operations Security (defined below), and the Construction Security shall be returned to the Seller promptly following delivery to the Purchaser of the Operations Security and the occurrence of the effective date of the Operations Security.

12.5.2 Operations Security

12.5.2.1 On the Commercial Operations Date, the Seller shall provide to the Purchaser security ("**Operations Security**") in the amount of [□] to ensure the completion and proper operation and maintenance of the Plant. The Operations Security shall be:

- (a) an unconditional and irrevocable direct pay letter of credit issued by a bank acceptable to the Purchaser in form and substance satisfactory to the Purchaser; and
- (b) adjusted in terms of amount from time to time in accordance with [Schedule 5 -].

12.5.2.2 The Operations Security may be applied to:

- (a) the payment of liquidated damages and accrued interest thereon in accordance with Clause 12.6; and

- (b) the payment of other Damages and interest that the Seller shall be required to pay to the Purchaser.

12.5.2.3 Except as expressly provided in this Agreement, the Seller shall maintain the Operations Security at the level designated in Clause 12.5.2.1 at all times; except that the Seller may have [] Days from the date the Purchaser gives notice to the Seller that it has retained or collected funds from the Operations Security pursuant to this Clause 12.5.2 to replenish the Operations Security so as to return it to the required level, as escalated.

12.5.2.4 Upon termination of this Agreement:

- (a) the Purchaser shall be entitled to retain or collect, as the case may be, from the Operations Security any Damages or moneys then due or reasonably expected to be due to the Purchaser by the Seller and shall pay or return to the Seller the remainder of the Operations Security and accrued interest, if any; and
- (b) if there is any matter between the Seller and the Purchaser that has been referred to an expert for determination or is being arbitrated pursuant to the Agreement, then the Purchaser shall be entitled to retain or collect, as the case may be, from the Operations Security, an amount equal to the Damages or moneys that the Purchaser, in its reasonable judgment, deems sufficient to satisfy any amount that may be due to the Purchaser by reason of such matter. Upon settlement or resolution of the matter, the Purchaser shall pay or return to the Seller the remaining amount of Operations Security.

12.6 [Maintenance Reserve]

To be considered on a case-by-case basis.

12.7 Payment of Liquidated Damages

12.7.1 The Parties agree that:

- 12.7.1.1 within seven (7) Days after the end of each Month, the Purchaser shall compute and advise the Seller by Liquidated Damages Notice of the amount of liquidated damages due to the Purchaser pursuant to this Agreement for the preceding Month;
- 12.7.1.2 each Party shall pay to the other Party, or, in the case of liquidated damages owed to the Purchaser, the Seller may, alternatively, direct the Purchaser to apply the Construction

Security or Operation Security (as the case may be) to, the amount of liquidated damages shown on a relevant Liquidated Damages Notice within thirty (30) Days after delivery of the Liquidated Damages Notice ("**Liquidated Damages Due Date**"), and interest shall accrue on any unpaid amount from the Liquidated Damages Due Date at the Default Rate; and

12.7.1.3 unless the entire amount of liquidated damages reflected on a Liquidated Damages Notice is paid to the Party to whom such liquidated damages are owed, the amount of such liquidated damages plus accrued interest due to that Party shall be added to, or set off against, amounts owed to the Seller by the Purchaser on the next statement(s) submitted to the Seller pursuant to Clause 12.8.

12.7.2 In the event that the amount of the liquidated damages plus accrued interest due to the Purchaser is greater than the amount which can be set off against any payments that are due and payable at the time the Liquidated Damages Notice is delivered to the Seller, the Purchaser may immediately deduct the sum due from the Construction Security or the Operation Security, as appropriate.

12.8 **Payment and Billing**

12.8.1 Within fifteen (15) Days after the end of each Month, the Seller shall prepare and deliver to the Purchaser a statement reflecting amounts payable to each Party by the other Party pursuant to this Agreement. Such statement shall:

12.8.1.1 include calculations, in reasonable detail, of such amounts owed to the Seller for Capacity Payments, Energy Payments, Supplemental Payments and liquidated damages and amounts owed to the Purchaser including liquidated damages, in accordance with this Agreement and the procedures determined by the Operating Committee; and

12.8.1.2 be accompanied by any payment of liquidated damages pursuant to Clause 12.7.1 .or a demand for payment owed to the Seller

12.8.2 Any payment which is not paid when due shall bear interest at the Default Rate.

12.8.3 If the Purchaser disputes any portion of such statement, then the Purchaser shall, within six (6) Days of the receipt of such statement, serve a notice on the Seller indicating the amount in dispute and the basis therefore ("**Payment Dispute Notice**"). The matter shall be settled by mutual discussion and, if necessary, referral to an expert pursuant to Clause 21.2. If it is determined that the either Party (the "**Debtor Party**") owes an amount of money to the other Party (the "**Creditor Party**"), the Debtor

Party shall, within six (6) Days after the receipt of such determination, pay such sum to the Creditor Party together with interest thereon at the Default Rate from the date the Debtor Party should have paid such sum to the Creditor Party.

- 12.8.4 At any time prior to [] Days after the end of an Operating Year, or within such other period as permitted or required by applicable law, either Party may serve a Payment Dispute Notice on the other Party that the amount of any statement submitted by the Purchaser during the preceding Operating Year is in dispute. Each Payment Dispute Notice shall specify the statement concerned, the amount of the Dispute and the basis thereof. The Dispute shall be settled by mutual discussion and, if necessary, referral to an expert pursuant to Clause 21.2. Upon resolution of the Dispute, the Party which is determined to owe money to the other Party shall immediately pay such sum to the other Party together with interest thereon at the Default Rate from the date such payment should have been made.

13. INSURANCE

13.1 Insurance Coverage

At all times during the Term, the Seller shall obtain and maintain at its own cost, or cause its Contractors to obtain and maintain, the insurances identified in Schedule 12

13.2 Endorsements

The Seller shall cause its insurers to amend its Comprehensive Commercial General Liability and, if applicable, Umbrella or Excess Liability policies with the endorsement items set forth in Clauses 13.2.1 through 13.2.5 below; and to amend the Seller's Employer Liability and Auto Liability policies with the endorsement item set forth in Clause 13.2.5 below:

- 13.2.1 the Purchaser, its directors, officers, and employees are additional insured under this policy;
- 13.2.2 this insurance is primary with respect to the interest of the Purchaser, its directors, officers, and employees and any other insurance maintained by them is excess and not contributory with this insurance;
- 13.2.3 the following Cross Liability section is made a part of the policy: "In the event of claims being made by reason of (a) personal and/or bodily injuries suffered by any employee or employees of one insured hereunder for which another insured hereunder is or may be liable, or (b) damage to property belonging to any insured hereunder for which another insured is or may be liable, then this policy shall cover such insured against whom a claim is made or may be made in the same manner as if separate policies have been issued to each insured hereunder, except with respect to the limits of insurance. However, the inclusion of more than one injured will

not operate to increase the limit of liability of the insured hereunder beyond the limit of liability in this policy.";

13.2.4 Insurer hereby waives all rights of subrogation against the Purchaser, its officers, directors and employees; and

13.2.5 notwithstanding any provision of the policy, this policy may not be cancelled, renewed, or materially changed by the insurer without giving thirty (30) Days prior written notice to the Purchaser. All other terms and conditions of the policy shall remain unchanged.

13.3 Use of Proceeds of All Risk/Operational Insurance

The proceeds of any All-Risks insurance obtained pursuant to Clause 13.1 shall, at the option of the Purchaser and subject to the Finance Parties' rights, be applied to the repair of the Plant.

13.4 Certificates of Insurance

The Seller shall cause its insurers or agents to provide the Purchaser with certificates of insurance evidencing the policies and endorsements listed above. Failure by the Seller to obtain the insurance coverage or certificates required by this Clause 13 of insurance shall not in any way relieve or limit the Seller's obligations or liabilities under any provision of this Agreement.

13.5 Premia and Deductibles

The Seller shall be solely responsible for the payment of all premia and deductibles under the policies of insurance maintained pursuant to this Clause 13.

13.6 Finance Parties' Interests

The Parties recognise and agree that insurances in respect of the Project will be secured in favour of the Finance Parties and that the interests of the Finance Parties will be noted on the insurance policies.

14. REPRESENTATIONS AND WARRANTIES OF THE PURCHASER

14.1 The Purchaser represents and warrants to the Seller that as at the Signature Date (which representations and warranties are deemed to be repeated on the Commercial Operations Date):

14.1.1 it has full power to carry on its business and to enter into, legally bind itself by, and perform its obligations under, this Agreement;

14.1.2 this Agreement has been duly authorized, executed, and delivered by it and constitutes its legal, valid and binding obligation;

14.1.3 the execution, delivery, and performance of this Agreement does not, and will not, constitute a violation of any statute, judgment, order, decree or regulation or rule of any court, governmental authority or arbitrator of

competent jurisdiction applicable or relating to it, its assets or its businesses;

- 14.1.4 there are no outstanding judgments against it and, no action, claim, suit or proceeding is pending or threatened against it before any court, governmental authority or arbitrator of competent jurisdiction that could reasonably be expected to affect materially and adversely the financial condition or operations of it or the ability of it to perform its obligations under this Agreement or which purports to affect the legality, validity or enforceability of this Agreement;
- 14.1.5 it is not in default under any agreement to which it is a party or by which it or its property may be bound, nor in any default of any technical or financial obligation, which could have a material adverse effect on the ability of it to perform its obligations under this Agreement; and
- 14.1.6 no information given by it in relation to this Agreement contains any misstatement of fact or omits to state a fact which would be materially adverse to the enforcement of the rights and remedies of the other Party or which would be necessary to make any statement, representation or warranty contained herein or therein true and correct in all material respects.

15. REPRESENTATIONS AND WARRANTIES OF THE SELLER

- 15.1 The Seller represents and warrants to the Purchaser that as at the Signature Date (which representations and warranties are deemed to be repeated by each Party on the Commercial Operations Date):
 - 15.1.1 the Seller is duly incorporated, validly existing and has complied fully with all requirements existing under the laws of the jurisdiction of its organisation or incorporation and all other applicable Laws of Tanzania;
 - 15.1.2 the Seller has full power to carry on its business and to enter into, legally bind itself by, and perform its obligations under, this Agreement and the other agreements comprising the Project Documents and/or the Security Package;
 - 15.1.3 this Agreement has been duly authorized, executed, and delivered by the Seller and constitutes its legal, valid and binding obligation;
 - 15.1.4 the execution, delivery, and performance of this Agreement and each agreement comprising the Security Package does not, and will not, constitute a violation of:
 - 15.1.4.1 any statute, judgment, order, decree or regulation or rule of any court, governmental authority or arbitrator of competent jurisdiction applicable or relating to the Seller, its assets or its businesses; or

- 15.1.4.2 the Seller's [NAME OF PRIMARY CONSTITUTIONAL DOCUMENTS, E.G., ARTICLES OF ASSOCIATION] or other organic documents or any indenture, contract or agreement to which it is a party or by which it or its property may be bound;
- 15.1.5 there are no outstanding judgments against the Seller it, and, to the best knowledge of [the Seller no action, claim, suit or proceeding is pending or threatened against the Seller before any court, governmental authority or arbitrator of competent jurisdiction that could reasonably be expected to affect materially and adversely the financial condition or operations of the Seller or the ability of the Seller to perform its obligations under this Agreement or any other agreement comprising the Security Package or which purports to affect the legality, validity or enforceability of this Agreement or any other agreement comprising the Security Package;
- 15.1.6 the Seller is not in default under any agreement to which it is a party or by which it or its property may be bound, nor in any default of any technical or financial obligation, which could have a material adverse effect on the ability of the Seller to perform its obligations under this Agreement or any other agreement comprising the Security Package; and
- 15.1.7 no information given by the Seller in relation to this Agreement or any agreement in the Security Package or in the proposal submitted by the Seller to the Purchaser in respect of the subject matter of this Agreement contains any misstatement of fact or omits to state a fact which would be materially adverse to the enforcement of the rights and remedies of the Purchaser or which would be necessary to make any statement, representation or warranty contained herein or therein true and correct in all material respects.

16. INDEMNIFICATION AND LIABILITY

16.1 Indemnity by the Seller

- 16.1.1 In addition to the Seller's obligations and the Purchaser's remedies provided elsewhere in this Agreement, the Seller will bear responsibility for loss of or damage to property, death or injury to person, and any other liabilities, damages, losses and reasonable costs and expenses (including reasonable legal fees and expert witness fees) (or any claim against the Purchaser in respect thereof) suffered by the Purchaser:
- 16.1.1.1 during the design, financing, construction, ownership, operation or maintenance of the Plant resulting from any negligent act or omission of, or wilful misconduct of, the Seller;
- 16.1.1.2 in connection with, arising out of, or resulting from, any breach of warranty, misrepresentation by the Seller, or non-performance of any term, condition, covenant or obligation to

be performed by the Seller under this Agreement or any other agreement comprising the Security Package; and

16.1.1.3 in connection with any claim, proceeding or action brought against the Purchaser under any applicable national or local environmental laws or regulations resulting from the Seller's [lease/ownership] of the Site or the Seller's ownership or operation of the Plant, including the discharge, dispersal, release, storage, treatment, generation, disposal or escape of pollutants or other toxic or hazardous substances from the Plant, the contamination of the soil, air, or water around the Site, or any pollution abatement, replacement, removal, or other decontamination or monitoring obligations with respect thereto.

16.1.2 The Seller will hold the Purchaser fully indemnified in respect of the foregoing losses, damages, death, injuries, liabilities, costs and expenses; except that the Seller's indemnities shall not extend to any loss, damage, death, injury, liability, costs or expenses (or any claim in respect thereof) to the extent that they (or a part thereof) were caused by any act or omission of the Purchaser or the failure of the Purchaser to take reasonable steps in mitigation thereof.

16.2 Indemnity by the Purchaser

16.2.1 In addition to the Purchaser's obligations and the Seller's remedies provided elsewhere in this Agreement, the Purchaser will bear responsibility for loss of or damage to property, death or injury to person, and any other liabilities, damages, losses and reasonable costs and expenses (including reasonable legal fees and expert witness fees) (or any claim against the Seller in respect thereof) suffered by the Seller:

16.2.1.1 during the design, financing, construction, ownership, operation or maintenance of the Plant resulting from any negligent act or omission of, or wilful misconduct of, the Purchaser;

16.2.1.2 in connection with, arising out of, or resulting from, any misrepresentation by the Purchaser or non-performance of any term, condition, covenant or obligation to be performed by the Purchaser under this Agreement; and

16.2.1.3 in connection with any claim, proceeding or action brought against the Seller under any applicable national or local environmental laws or regulations resulting from the Purchaser's ownership or operation of the Interconnection Facilities or the Purchaser Grid System, including the discharge, dispersal, release, storage, treatment, generation, disposal or escape of pollutants or other toxic or hazardous substances from the Interconnection Facilities or the Purchaser Grid System, the contamination of the soil, air, or water around the Interconnection Facilities or the Purchaser Grid System, or

any pollution abatement, replacement, removal, or other decontamination or monitoring obligations with respect thereto.

16.2.2 The Purchaser will hold the Seller fully indemnified in respect of the foregoing losses, damages, death, injuries, liabilities, costs and expenses; except that the Purchaser's indemnities shall not extend to any loss, damage, death, injury, liability, cost or expense (or any claim in respect thereof) to the extent that it (or a part thereof) was caused by any act or omission of the Seller or the failure of the Seller to take reasonable steps in mitigation thereof.

16.3 **Joint Negligence**

In the event injury or damage results from the joint or concurrent negligent or intentional acts or omissions of the Parties, each Party shall be liable under this indemnification in proportion to its relative degree of fault.

16.4 **No Indemnification for Fines and Penalties**

Any fines or other penalties incurred by a Party for non-compliance with Laws of Tanzania shall not be reimbursed by the other Party but shall be the sole responsibility of the non-complying Party. The non-complying Party shall have the right, but not the obligation, to contest or appeal any fines it believes have been imposed in violation of the Laws of Tanzania.

16.5 **Notice of Proceedings**

Each Party shall promptly notify the other Party of any claim or proceeding in respect of which, but for the provisions of Clause 16.6, it is entitled to be indemnified under this Clause. Such notice shall be given as soon as reasonably practicable after the relevant Party becomes aware of such claim or proceeding.

16.6 **Basket Limitation**

16.6.1 Neither Party shall be entitled to make any claim under this Clause 16 until such time as all such claims by such Party exceed [] in the aggregate or until such claim if not made would be barred by the relevant statute of limitations, at which time all such claims of that Party may be made.

16.6.2 When any claim is made under this Clause 16, the limit in Clause 16.6.1 above shall apply in respect of future claims.

16.6.3 Notwithstanding the foregoing, any claims outstanding at the termination or expiration of this Agreement may be brought at that time.

16.7 **Conduct of Proceedings**

16.7.1 Each Party shall have the right, but not the obligation, to contest, defend and litigate (and to retain legal advisers of its choice in connection therewith) any claim, action, suit or proceeding by any third party alleged

or asserted against it arising out of any matter in respect of which it is entitled to be indemnified hereunder, and the reasonable costs and expenses thereof shall be subject to the said indemnity.

- 16.7.2 Notwithstanding the above, the indemnifying Party shall be entitled, at its option, to assume and control the defence of such claim, action, suit or proceeding at its expense and through legal advisers of its choice if it:
- 16.7.2.1 gives notice of its intention to do so to the other Party;
 - 16.7.2.2 acknowledges in writing its obligation to indemnify that Party to the full extent provided by this Clause 16; and
 - 16.7.2.3 reimburses that Party for the reasonable costs and expenses previously incurred by it prior to the assumption of such defence by the indemnifying Party.
- 16.7.3 Neither Party shall settle or compromise any claim, action, suit or proceeding in respect of which it is entitled to be indemnified by the other Party without the prior written consent of that Party; provided always that after agreeing in writing to indemnify the indemnified Party, the indemnifying Party may settle or compromise any such claim, action, suit or proceeding without the approval of the indemnified Party.

17. CHANGE IN LAW

- 17.1 In the event of any Change in Law, the Seller shall promptly notify the Purchaser, providing reasonable details of the impact of such Change in Law.
- 17.2 Following such notice, the Parties shall meet and consult in good faith, as soon as reasonably practicable and in any event no later than thirty (30) days from the date of the Seller's notice, with a view to agreeing on appropriate measures, such as, adjustments to the Tariff or any component thereof and/or amendments to this Agreement, to restore the Seller to the same economic equilibrium it would have been in had such Change in Law not occurred, on a no better and no worse basis.
- 17.3 Any agreed adjustment, amendment or relief shall be implemented and/or paid within sixty (60) days of the Parties reaching agreement, in accordance with the provisions of this Agreement.
- 17.4 For the avoidance of doubt, any Change in Law affecting only the Government's obligations under the Implementation Agreement (IA) shall be addressed exclusively under the IA and not under this Clause.
- 17.5 Any disagreement regarding the existence, scope, or effect of a Change in Law under this Clause shall be resolved in accordance with the dispute resolution provisions of this Agreement.

17.6 Provided that, the Seller shall not be entitled to recover the same costs, losses or impacts more than once, and any relief granted under this Agreement shall be taken into account in determining any entitlement under the Implementation Agreement.

18. FORCE MAJEURE

18.1 Meaning of Force Majeure

In this Agreement, "Force Majeure" means any event or circumstance or combination of events or circumstances beyond the reasonable control of the Party affected by such event, circumstance or combination of events or circumstances (the "**Affected Party**");

- (i) which could not have been prevented or avoided or overcome by the Party acting as a Reasonable and Prudent Operator;
- (ii) which materially and adversely affects the performance by that Party of its obligations or the enjoyment by that Party of its rights under or pursuant to this Agreement; and
- (iii) is not the direct result of a breach by the Affected Party of any other Project Document to which it is a party.

Without limitation to the generality of the foregoing, "Force Majeure" shall include the following events and circumstances to the extent that they satisfy the above requirements:

18.1.1 natural events ("**Force Majeure - Natural**") including:

- 18.1.1.1 acts of God (including lightning, fire, earthquake, volcano eruption, flood, storm, hurricane, cyclone, typhoon, tidal wave and tornado);
- 18.1.1.2 epidemic or plague;
- 18.1.1.3 explosion or chemical contamination (other than resulting from an event or circumstance described in Clause 18.1.2.1(a), in which case it shall be a Tanzania Political Event); and

18.1.2 other events of Force Majeure ("**Force Majeure - Political**") including:

- 18.1.2.1 Force Majeure - Political which occurs inside or directly involves Tanzania ("**Tanzania Political Events**") including:
 - (a) any act of war (whether declared or undeclared), invasion, armed conflict or act of foreign enemy, blockade, embargo, revolution, riot, insurrection, civil commotion, or act of terrorism;
 - (b) nationwide strikes, works to rule or go-slows that extend beyond the Plant or are widespread or

nationwide, or that are of a political nature, such as, by way of example and not limitation, labour actions associated with or directed against a Tanzania political party, or those that are directed against the Seller (or its Contractors) as a part of a broader pattern of labour actions against companies or facilities with foreign ownership or management;

- (c) any unlawful, unauthorised or ultra vires revocation of, or refusal (without valid cause) to grant or renew, any clearance, licence, permit, authorisation, no-objection certificate, consent, approval or exemption required by the Project Company to perform its obligations under this Agreement; provided that such delay, modification, denial, refusal or revocation does not result from the Project Company's failure or inability to comply with any condition relating to the grant, maintenance or renewal of such clearance, licence, permit, authorisation, no-objection certificate, consent, approval or exemption;
- (d) radioactive contamination or ionizing radiation originating from a source in Tanzania or resulting from another Tanzania Political Event;
- (e) any Lapse of Consent; and
- (f) any event or circumstance constituting a Tanzania Political Event under the Implementation Agreement.

18.1.2.2 Force Majeure - Political which occurs outside Tanzania and does not directly involve Tanzania ("**Foreign Political Events**") including:

- (a) any act of war (whether declared or undeclared), invasion, armed conflict or act of a foreign enemy, blockade, embargo, revolution, riot, insurrection, civil commotion, act of terrorism, or sabotage;
- (b) strikes, work-to-rule or go-slows that are widespread or nationwide;
- (c) radioactive contamination or ionizing radiation originating from a source outside Tanzania and not falling within Clause 18.1.2.1(c); and

18.1.2.3 "**Force Majeure**" shall expressly not include the following conditions:

- (a) [normal wear and tear or inherent flaws in materials and equipment or breakdowns of equipment;
- (b) the economic hardship of an Affected Party or changes in market conditions;
- (c) any event caused by, or connected with, the Affected Party's (i) negligent or intentional acts, errors or omissions, (ii) failure to comply with any laws or (iii) breach of, or default under, this Agreement;
- (d) unavailability of electric transmission or distribution service sufficient to export the output of the Plant in whole or part, except to the extent such unavailability is itself due to Force Majeure;
- (e) failure to make a payment of money in accordance with the Seller's obligations under this Agreement;
- (f) any failure to take into account prevailing Site conditions;
- (g) inability to obtain or maintain adequate funding; and
- (h) delays resulting from reasonably foreseeable unfavourable weather conditions or other similar reasonably foreseeable adverse conditions.

18.2 Notification and Obligation to Remedy

In the event of the occurrence of a Force Majeure that prevents a Party from performing its obligations hereunder (other than an obligation to pay money), such Party shall:

- 18.2.1 notify as soon as reasonably practicable the other Party in writing of such Force Majeure;
- 18.2.2 not be entitled to suspend performance under this Agreement for any greater scope or longer duration than is required by the Force Majeure;
- 18.2.3 use all reasonable efforts to remedy its inability to perform and to resume full performance hereunder as soon as practicable;
- 18.2.4 keep the other Party apprised of such efforts on a continuous basis; and
- 18.2.5 provide written notice of the resumption of performance hereunder. Notwithstanding the occurrence of a Force Majeure, the Parties shall perform their obligations under this Agreement to the extent the performance of such obligations is not impeded by the Force Majeure.

18.3 Consequences of Force Majeure

- 18.3.1 During the pendency of a Force Majeure other than a Tanzania Political Event, the Seller shall not be entitled to receive Capacity Payments or Energy Payments or Supplemental Payments from the Purchaser; except that if such Force Majeure affects only part of the Plant, then the Capacity Payments and Supplemental Payments during the pendency of such Force Majeure shall be pro-rated to reflect the portion of the Plant not affected thereby, and the Seller shall be entitled to receive such pro-rated Capacity Payments and Supplemental Payments and Energy Payments for electrical energy actually delivered to the Purchaser.
- 18.3.2 For the avoidance of doubt, where a Force Majeure Event arises from or constitutes a Tanzania Political Event, the Seller's entitlement to any relief or compensation shall be governed exclusively by the Implementation Agreement. Accordingly, the Purchaser shall have no obligation under this Agreement to compensate the Seller in respect of any Force Majeure Event addressed under the Implementation Agreement.
- 18.3.3 Neither Party shall be responsible or liable for, or deemed in breach hereof because of, any failure or delay in complying with its obligations under or pursuant to this Agreement which it cannot perform due solely to one or more Force Majeure or its or their effects or by any combination thereof.
- 18.3.4 The periods allowed for the performance by the Parties of the obligation(s) referred to in Clause 18.3.1 shall be extended on a day-for-day basis for so long as one or more Force Majeure continues to affect materially and adversely the performance of such Party of such obligation(s) under or pursuant to this Agreement.
- 18.3.5 Notwithstanding Clauses 18.3.1 and 18.3.4 above, no relief shall be granted to the Party claiming Force Majeure pursuant to this Clause 18.3 to the extent that such failure or delay would have nevertheless been experienced by that Party had such Force Majeure not occurred.
- 18.3.6 the Party not claiming Force Majeure may immediately terminate this Agreement without further obligation, by delivering a Termination Notice on the other Party, or deliver a Transfer Notice in accordance with Clause 20.5, if an event of Force Majeure delays the other Party's performance for a period greater than (a) six (6) consecutive Months prior to the Commercial Operations Date or (b) three (3) consecutive Months after the Commercial Operations Date.

19. TAXES

- 19.1 All present and future national, local or other lawful taxes, duties, levies, or other impositions applicable to the Seller, the Plant, the Project and the Seller's other assets shall be paid by the Seller in accordance with the laws of Tanzania.

19.2 All present and future national, local or other lawful taxes, duties, levies, or other impositions applicable to the Purchaser arising from or in connection with its rights and obligations under this Agreement shall be paid by the Purchaser in accordance with the laws of Tanzania.

20. DEFAULTS AND TERMINATION

20.1 Seller Events of Default

Each of the following events shall be events of default by the Seller (each a "**Seller Event of Default**"), which, if not cured within the time permitted (if any) under Clause 20.4, shall give rise to the right on the part of the Purchaser to terminate this Agreement pursuant to Clause 20.4.3:

- 20.1.1 the failure of the Seller to post the Construction Security in accordance with Clause 12.5.1 on or before Financial Closing;
- 20.1.2 the failure of the Seller to achieve the Commencement of Construction within ninety (90) Days after Financial Closing;
- 20.1.3 the Abandonment by the Seller of the construction of the Plant after the Commencement of Construction without the written consent of the Purchaser;
- 20.1.4 the failure of the Seller to achieve the Commercial Operations Date within One Hundred Eighty (180) Days after the Required Commercial Operations Date;
- 20.1.5 the failure of the Seller to provide or replenish the Operations Security in accordance with Clause 12.5.2 of this Agreement;
- 20.1.6 the Abandonment by the Seller of the operation of the Plant without the written consent of the Purchaser;
- 20.1.7 the failure of the appointment or replacement by the Seller of a Construction Contractor or an O&M Contractor or any [material] amendment to or waiver of any terms of the Construction Contract or the O&M Contract without the prior consent of the Purchaser;
- 20.1.8 the assignment or transfer of this Agreement or an assignment, transfer or acquisition in breach of Clause 22.1 or 22.2 of this Agreement;
- 20.1.9 any failure by the Seller to make any payment or payments required to be made by it under this Agreement within forty -five (45) Business Days after the Seller is given notice that the payment was not made by the due date for payment;
- 20.1.10 except for the purpose of amalgamation, reorganization or reconstruction (provided that such amalgamation, reorganization or reconstruction does not affect the ability of the amalgamated, reorganized or reconstructed

entity, as the case may be, to perform its obligations under this Agreement), the occurrence of any of the following events:

- 20.1.10.1 the passing of a resolution by the owners of the Seller for the winding up of the Seller;
- 20.1.10.2 the admission in writing by the Seller of its inability generally to pay its debts as they become due;
- 20.1.10.3 the appointment of a provisional manager, trustee, liquidator or similar person in a winding up proceeding after notice to the Seller and due hearing; or
- 20.1.10.4 the making by a court with competent jurisdiction over the Seller of an order winding up the Seller;
- 20.1.11 reduction of the Dependable Capacity to less than [] MW for a period of at least 12 consecutive Months;
- 20.1.12 any representation, warranty or statement made, repeated or deemed made by the Seller which was (or proves to have been) incomplete, untrue, incorrect or misleading when made or deemed to have been made;
- 20.1.13 any [material] breach by the Seller of this Agreement, which breach has a [material and] adverse impact on the Purchaser,

except that none of the events described above in Clauses 20.1.1 to 20.1.13 (inclusive) shall be a Seller Event of Default hereunder if (i) it results from a breach by the Purchaser of this Agreement; or (ii) if it occurs as a result of a Force Majeure for the period provided pursuant to Clause 18.3.

20.2 Purchaser Events of Default

Each of the following events shall be events of default by the Purchaser (each a "**Purchaser Event of Default**"), which, if not cured within the time permitted (if any) under Clause 20.4, shall give rise to the right on the part of the Seller to terminate this Agreement pursuant to Clause 20.4.4:

- 20.2.1 [except for the purpose of amalgamation, reorganization or reconstruction (provided that such amalgamation, reorganization or reconstruction does not affect the ability of the amalgamated, reorganized or reconstructed entity, as the case may be, to perform its obligations under this Agreement), the occurrence of any of the following events:
 - 20.2.1.1 the passing of a resolution by the shareholders of the Purchaser for the winding up of the Purchaser;
 - 20.2.1.2 the admission in writing by the Purchaser of its inability generally to pay its debts as they become due;

- 20.2.1.3 the appointment of a provisional manager, trustee, liquidator or similar person in a winding up proceeding after notice to the Purchaser and due hearing; or
- 20.2.1.4 the making by any court with competent jurisdiction over the Purchaser of an order winding up the Purchaser;]
- 20.2.2 any failure by the Purchaser to make any payment or payments required to be made by it under this Agreement within forty-five (45) Days after the Purchaser is given notice that the payment was not made by the due date for payment;
- 20.2.3 the assignment or transfer of this Agreement or an assignment, transfer or acquisition in breach of Clause 22.1 of this Agreement; or
- 20.2.4 any [material] breach by the Purchaser of this Agreement, which breach has a [material and] adverse impact on the Seller; provided, however, that a breach which, with the passing of time or the fulfilment of any other condition specified in Clauses 20.2.1 to 20.2.3 above, would constitute an event or circumstance falling within any such clause shall not be a the Purchaser Event of Default under this Clause 20.2.4,

except that none of the events described above in Clauses 20.2.1 - 20.2.4 (inclusive) shall be a Purchaser Event of Default hereunder if (i) it results from a breach by the Seller of this Agreement; or (ii) if it occurs as a result of a Force Majeure for the period provided pursuant to Clause 18.3

20.3 Termination of the Implementation Agreement

In the event that the Implementation Agreement is terminated prior to the expiry of this Agreement for any reason, such termination shall constitute a termination event under this Agreement. For the avoidance of doubt, the termination of the Implementation Agreement shall not relieve the parties of any obligations accrued under this Agreement prior to such termination.

20.4 Notice and Cure

- 20.4.1 In the case of a Purchaser Event of Default or a Seller Event of Default (each, an "**Event of Default**"), as the case may be, set forth in Clause 20.1 or Clause 20.2, the defaulting Party shall have forty five (45)Days to cure the Event of Default, to the extent that Event of Default can be cured. If such Event of Default is incapable of being cured within that period, the defaulting Party may request from the non-defaulting Party an additional period not exceeding forty-five (45) Days to cure the Event of Default, and approval by the non-defaulting Party of such request shall not be unreasonably withheld or delayed. The defaulting Party shall furnish to the non-defaulting Party during any cure period weekly reports on its progress in curing the Event of Default.

- 20.4.2 Should an Event of Default not be cured within the timeframe permitted pursuant to Clause 20.4.1, the non-defaulting Party may terminate this Agreement by serving a Termination Notice on the defaulting Party or, alternatively, may serve a Transfer Notice pursuant to Clause 22.5.
- 20.4.3 Notwithstanding the rights in Clause 20.4.2 the Purchaser will not exercise any right to terminate or suspend this Agreement unless it shall have given the Lenders prior written notice of its intent to terminate or suspend this Agreement, as required by this Agreement, specifying the condition giving rise to such right, and the Lenders shall not have caused to be cured the condition giving rise to the right of termination or suspension within thirty (30) days after such notice or (if longer) the periods provided for in this Agreement; provided that if such Provider default reasonably cannot be cured by the Lenders within such period and the Lenders commences and continuously pursues cure of such default within such period, such period for cure will be extended for a reasonable period of time under the circumstances, such period not to exceed additional ninety (90) days. The Purchaser's and Seller's respective obligations will otherwise remain in effect during any cure period.
- 20.4.4 Notwithstanding the rights in Clause 20.4.2 the Seller shall not exercise any right to terminate or suspend this Agreement unless it shall have given the GoT prior written notice of its intent to terminate or suspend this Agreement, as required by this Agreement, specifying the condition giving rise to such right, and the GoT shall not have caused to be cured the condition giving rise to the right of termination or suspension within thirty (30) days after such notice or (if longer) the periods provided for in this Agreement; provided that if such Provider default reasonably cannot be cured by the Purchaser within such period and the Purchaser commences and continuously pursues cure of such default within such period, such period for cure will be extended for a reasonable period of time under the circumstances, such period not to exceed additional ninety (90) days. The Purchaser's and Seller's respective obligations will otherwise remain in effect during any cure period.

20.5 Rights and Remedies Upon an Event of Default

20.5.1 Seller Event of Default

- 20.5.1.1 If a Seller Event of Default has occurred and that Seller Event of Default has not been cured within the period specified in Clause 20.4, the Purchaser, in its sole discretion, may:
- (a) immediately terminate this Agreement by serving a Termination Notice on the Seller or, alternatively, may serve a Transfer Notice pursuant to Clause 20.6; and/or

- (b) proceed in accordance with Clause 21 to protect and enforce its rights, to recover any Damages to which it may be entitled (including all costs and expenses reasonably incurred in the exercise of its remedy); and/or
 - (c) retain all or part of the Construction Security and/or the Operations Security provided by the Seller pursuant to Clause 12.4 in full or partial satisfaction of the Damages to which it may be entitled under Clause 20.5.1.1(b) above.
- 20.5.1.2 These rights and remedies shall not be exclusive but, to the extent permitted by law, shall be cumulative and in addition to all other rights and remedies existing at law, in equity or otherwise, provided that, the Purchaser may only seek to exercise such rights and remedies in accordance with the procedures set forth in Clause 21.
- 20.5.1.3 The Purchaser may exercise each right and remedy afforded by this Agreement or by law from time to time and as often as may be deemed expedient by the Purchaser.
- 20.5.1.4 No delay by, or omission of, the Purchaser to exercise any right or remedy arising upon any Seller Event of Default shall impair any such right or remedy or constitute a waiver of such event or an acquiescence thereto.
- 20.5.2 Purchaser Event of Default
 - 20.5.2.1 If a Purchaser Event of Default has occurred and the Purchaser Event of Default has not been cured within the period specified in Clause 20.4, the Seller, in its sole discretion, may:
 - (a) immediately terminate this Agreement by serving a Termination Notice on the Purchaser or, alternatively, may serve a Transfer Notice pursuant to Clause 20.6; and/or
 - (b) proceed in accordance with Clause 21 to protect and enforce its rights and to recover any Damages to which it may be entitled (including all costs and expenses reasonably incurred in the exercise of its remedy).
 - 20.5.2.2 These rights and remedies shall not be exclusive but, to the extent permitted by law, shall be cumulative and in addition to all other rights and remedies existing at law, in equity or otherwise, provided that the Seller may only seek to exercise such rights and remedies in accordance with the procedures set forth in Clause 21.

20.5.2.3 the Seller may exercise each right and remedy afforded by this Agreement or by law from time to time and as often as may be deemed expedient by the Seller.

20.5.2.4 No delay by, or omission of, the Seller to exercise any right or remedy arising upon any the Purchaser Event of Default shall impair any such right or remedy or constitute a waiver of such event or an acquiescence thereto.

20.6 Option to transfer upon right of termination

20.6.1 If a Party wishes to exercise an option expressed to be in favour of it pursuant to this Clause 20.5, it shall do so by serving a notice (a "**Transfer Notice**") to the other Party in accordance with Clause 20.6 requiring, in the case of a Transfer Notice served by the Purchaser, that the Seller sells and transfers the Transferred Assets or, in the case of a Transfer Notice served by the Seller, that the Purchaser accepts transfer of the Transferred Assets, in each case in return for payment of the Termination Payment (if any) and in accordance with this Clause 20.

20.6.2 In the event that the Purchaser is entitled to terminate this Agreement, the Purchaser shall have the option, but not the obligation, to serve a Transfer Notice on the Seller.

20.6.3 In the event that the Seller is entitled to terminate this Agreement, the Seller shall have the option, but not the obligation, to serve a Transfer Notice on the Purchaser.

20.6.4 The Purchaser shall be entitled, but not obligated, to serve a Transfer Notice within a period of thirty (30) days following the date on which this Agreement expires at the end of the Term (including any extension to the Term agreed in accordance with Clause 2).

20.6.5 If a Transfer Notice is properly issued pursuant to this Clause 20.5, the Seller shall transfer the Transferred Assets to the Purchaser, and the Purchaser shall pay any applicable Termination Payment thereof in each case as determined pursuant to Clauses 20.6 to 20.8 and Schedule 11 -.

20.7 Exercising option to transfer

20.7.1 Any Transfer Notice served by the Seller to the Purchaser pursuant to Clause 20.5 shall be served on the GoT at the same time.

20.7.2 If either Party has a right to terminate this Agreement and fails to serve a valid Transfer Notice under this Clause prior to exercising that right or within one hundred and twenty (120) Business Days of that right arising, that Party shall be presumed to have waived its rights to require the other Party to sell and transfer or, as the case may be, to purchase and accept a transfer of, the Transferred Assets pursuant to Clause 20.5 as a result of the event giving rise to that right to terminate.

- 20.7.3 The Seller shall, promptly on receipt of any request from the Purchaser after the Purchaser becomes entitled to serve a Transfer Notice, make available to the Purchaser:
- 20.7.3.1 all data or records relating to the operation and maintenance of the Plant in its possession; and
 - 20.7.3.2 all other information or records relating to the Seller, its business, assets and liabilities in its possession,
- in each case, as the Purchaser reasonably requests and is necessary for the purpose of determining the likely Termination Payment.
- 20.7.4 Notwithstanding any other provision of this Agreement, if either Party serves a Transfer Notice on the other Party, then the Purchaser shall be entitled to enter the Site and operate the Plant using the same operating standards which it uses to operate its own generating facilities acting as a Reasonable and Prudent Operator until the Asset Transfer Date. The Purchaser shall, during the period it operates the Plant pursuant to this Clause, bear all costs of such operation (including fixed, Fuel and variable costs), and it shall be obligated to pay the Seller an amount sufficient to cover the equivalent of the debt service component and fixed operation and maintenance component of the Capacity Payment as calculated under Clause 12.1 and Schedule 5 -. At its option, the Purchaser shall also either:
- 20.7.4.1 pay for the cost of any fuel and lubricating oil in the Seller's storage facilities which the Seller has paid for and which the Purchaser has used to operate the Plant; or
 - 20.7.4.2 replace such Fuels and lubricating oil supplies upon resumption of operation by the Seller.
- 20.7.5 During any period that the Purchaser shall operate the Plant pursuant to Clause 20.6.4 above, the Seller shall be paid only the debt service element of the Capacity Payment and shall not be entitled to any other Capacity Payments or Energy Payments.
- 20.7.6 Notwithstanding the provisions of Clause 16.2, the Purchaser shall only indemnify and hold the Seller harmless from any loss or damage to the Plant for losses, claims, damages or liabilities incurred, suffered or sustained by the Seller by reason of the Purchaser's negligence or wilful misconduct in the operation of the Plant during such period, and then only to the extent that such loss or damage is not covered by insurance.

20.8 Terms and conditions of transfer

- 20.8.1 The Seller shall, on the Asset Transfer Date, transfer all right, title and interest in the Transferred Assets to the Purchaser.

- 20.8.2 The Termination Payment shall be calculated in US Dollars and shall be payable in a combination of [the Local Currency] and [US Dollars] within one hundred and twenty (120) Business Days of the Asset Transfer Date and in accordance with Clause 20.7.3, and for the avoidance of doubt, the portion of the Termination Payment equal to the Project Debt shall be payable in [US Dollars].
- 20.8.3 Any Termination Payment shall be wired directly into such account or accounts inside or outside of Tanzania as directed by the Seller, except that the portion of the Termination Payment equal to the Project Debt shall, be payable as directed by the Lenders in writing to the Purchaser and the GoT or pursuant to any direct agreement between the Purchaser and the Lenders.
- 20.8.4 For the purposes of the transfer pursuant to this Clause, the "**Transferred Assets**" shall include:
- 20.8.4.1 the Plant (in any stage of development, construction, commissioning and/or operation);
 - 20.8.4.2 the Seller's rights title and interest to all assignable third-party warranties and guarantees relating thereto in each case, free and clear of all encumbrances;
 - 20.8.4.3 all rights of the Seller to occupy the Site, together with all buildings, plant and equipment, stocks of spare parts, Fuel and all other consumables (other than personal belongings of the staff of the Seller or any or its Contractors or agents) necessary for the construction, operation, maintenance and repair of the Plant and in the ownership of the Seller on the Asset Transfer Date, any assignable outstanding insurance claims and the benefit of any insurance policies;
 - 20.8.4.4 to the extent only that they are assignable, the benefit of all existing agreements or orders (including the Project Documents insofar as the same remain in force) relating to the Project, the Plant, its construction, operation, maintenance and repair and all records and assets relating to the Plant and the Plant Site;
 - 20.8.4.5 the trade and book debts and receivables accruing due to the Seller prior to but unpaid at the Asset Transfer Date;
 - 20.8.4.6 the benefit of claims under warranties, guarantees, conditions, indemnities, insurance policies and otherwise howsoever arising out of any events occurring or circumstances arising prior to the Asset Transfer Date and outstanding claims under warranties, guarantees, conditions, indemnities and otherwise; and

- 20.8.4.7 the benefit of any refund or repayment of any taxes becoming payable after but attributable to the construction, operation, maintenance or repair of, or the sale of the Dependable Capacity of, Net Energy Output delivered by, and Ancillary Services provided by, the Plant prior to the Asset Transfer Date.
- 20.8.5 On the Asset Transfer Date, the Transferred Assets shall be transferred to the Purchaser with no representations or warranties provided by the Seller, whether express or implied, in respect of the Transferred Assets, including the condition of the Plant or any Unit thereof.
- 20.8.6 On the Transfer Date, the Parties shall enter into all such notarial deeds, transfers, releases and documents as are necessary to give effect to the requirements of this Clause. If on the Asset Transfer Date any of the Transferred Assets is the subject of any encumbrance, the Seller shall (subject to any payments to be made to directly by the Purchaser to Lenders pursuant to Clause 20.7.3 or unless the Purchaser otherwise agrees) immediately on receipt apply the Termination Payment *pro tanto* in discharge of any such encumbrance, so as to obtain the prompt release of the same.
- 20.8.7 On the Asset Transfer Date, the Seller shall assign to the Purchaser (in each case only to the extent assignable) or use reasonable endeavours to assist in the renewal or novation in favour of the Purchaser in place of the Seller of all agreements with third parties (including all the Project Documents and any the Seller Consents) insofar as the same remain in force and which are necessary for the continued construction, operation, maintenance or repair of the Plant and the Site, where such assignment, renewal or novation is permitted by applicable law or by the terms of the particular agreement.
- 20.8.8 If this Agreement is terminated by the Seller as a result of a Purchaser Event of Default or a Tanzania Political Event, all stamp duties and other Taxes in respect of the transfer of the Transferred Assets pursuant to a Transfer Notice and any registration fees shall be borne by the Purchaser. If this Agreement is terminated by the Purchaser as a result of a Seller Event of Default, such stamp duties and Taxes shall be borne by the Seller. If this Agreement is terminated for any other reason, such stamp duties and taxes shall be borne by the Parties in equal proportions.

20.9 Transfer Procedures

- 20.9.1 If a Party has issued a Transfer Notice, then the Seller shall prepare a draft statement (a "**Termination Statement**") setting out the information prescribed by the provisions of Schedule 1 -. This Termination Statement shall be prepared and delivered to the Purchaser within [thirty (30)] days of the date of the Transfer Notice, or if a Valuer is appointed pursuant to Clause 20.8.2 to calculate the FMV of the Plant, within [five (5)] days of receipt by the Purchaser of the Valuer's certification of the FMV. The

Seller shall provide the Purchaser with all information in relation to its calculations of the amounts set forth in the Termination Statement as the Purchaser may reasonably request.

- 20.9.2 If, pursuant to Schedule 1 -, the Transfer Value in relation to a Transfer Notice is to be FMV (or the lesser of DBV and FMV), then within [five (5)] days of the date of that Transfer Notice, the Parties shall appoint an independent firm of chartered surveyors to calculate and certify FMV (in accordance with Schedule 1 -). If the Parties fail to agree on the firm of chartered surveyors within this period, then either Party may request [the President of the Royal Institution of Chartered Surveyors of England and Wales] to appoint the firm. The firm agreed by the Parties, or in default of agreement, appointed by the President of the Royal Institution of Chartered Surveyors, shall be the "**Valuer**" for the purposes of this Agreement. The Valuer shall be responsible for certifying the FMV as at the date of the Transfer Notice. The Parties shall request the Valuer to complete his valuation within [fifteen (15)] days of his appointment and issue copies of his valuation and certificate to the Parties. The Valuer shall be entitled to have access to the Plant Site and to the Seller's books and records and other relevant documents and information as he may reasonably require for the purposes of calculating and certifying the FMV. The certification of the FMV by the Valuer shall, in the absence of fraud or manifest error, be final and binding on the Parties. The provisions of Clause 20.8.8 shall apply *mutatis mutandis* to the Valuer's reasonable costs and expenses incurred in determining the FMV.
- 20.9.3 The Purchaser shall be entitled to query the correctness of the draft Termination Statement by notice to the Seller, setting out its objections and, if appropriate, its proposed amendments, within [thirty (30)] days of receiving it. If the Purchaser fails to so notify the Seller within this period, the Termination Statement shall be deemed approved and shall become the Termination Statement for the purposes of this Agreement. Having served such a notice, if the Parties then fail to reach agreement on the amendments to be made to the draft Termination Statement within a further [thirty (30)] days from the date of the Purchaser's notice setting out its objections, either Party may submit the matter to an expert in accordance with Clause 21.2. If the Parties fail to refer a matter to an expert within this period, then the Seller shall be deemed to have approved the draft Termination Statement as amended by the Purchaser, and the draft Termination Statement as amended by the Purchaser shall become the Termination Statement for the purposes of this Agreement.
- 20.9.4 Notwithstanding Clause 20.2.14, following any determination by the expert of a matter referred to him pursuant to Clause 20.9.3, either Party shall be entitled to dispute the expert's determination and refer that Dispute or any Dispute in relation to the Termination Statement to arbitration in accordance with Clause[], within [thirty (30)] days of receipt of the expert's written determination of the matter referred to him. If no reference is made to arbitration within that period, then the expert's

determination shall be final and binding on the Parties (and shall not be subject to further appeal by way of arbitration or legal proceedings or otherwise) and the draft Termination Statement shall be deemed amended by his determination, deemed approved by the Parties as so amended and shall become the Termination Statement for the purposes of this Agreement.

20.9.5 Completion of the transfer of the Transferred Assets pursuant to a Transfer Notice shall take place on the Asset Transfer Date at [the head office] of the Purchaser at such time as the Purchaser shall notify the Seller (such time to notified not later than 10.00 hours on the fifth Day prior to the Asset Transfer Date). Upon completion of the transfer, this Agreement shall terminate, other than those provisions stated to survive termination of this Agreement in Clause 24.7.

20.9.6 Subject to Clause 20.8.1, the "**Asset Transfer Date**" shall be the tenth (10th) Business Day following:

20.9.6.1 if a matter is referred for resolution in accordance with Clauses 20.9.3 or 20.9.4, the date that the matter is so resolved, or otherwise settled by the Parties; or

20.9.6.2 otherwise, the date the Termination Statement is agreed or deemed approved pursuant to Clauses 20.9.3 or 20.9.4, as the case may be.

20.10 **Consequences of Termination**

Upon termination of this Agreement, both Parties shall be excused and relieved of all obligations and liabilities under this Agreement, except for (i) payment of all amounts due; (ii) liabilities resulting from any action, inaction or event occurring before the Termination Date and (iii) liabilities expressly survive such termination pursuant to Clause 24.7.

20.11 **Obligations Upon Termination**

Upon expiration or termination of this Agreement, the Parties shall have no further obligations or liabilities hereunder except for those obligations and liabilities that (i) arose prior to such termination, or (ii) survive termination pursuant to Clause 24.7.

21. **RESOLUTION OF DISPUTES**

21.1 **Mutual Discussions**

21.1.1 If any dispute or difference of any kind whatsoever ("**Dispute**") shall arise between the Purchaser and the Seller in connection with, or arising out of, this Agreement, the Parties shall attempt in good faith to settle such Dispute in the first instance within thirty (30) Days by mutual discussions between the Seller and the Purchaser, which may include referring the Dispute to the Operating Committee for resolution within such thirty (30)

Day period. The Parties shall commence such discussions within fifteen (15) Days of a request by either Party.

- 21.1.2 In the event that a Dispute is not resolved by discussion in accordance with above Clause 21.1.1, within the time periods set forth therein, either Party may (but shall not be compelled to) refer the Dispute to the Chief Executive Officer of the Seller (or another authorized director or officer of the Seller designated by notice to the Purchaser in writing) and the Chief Executive Officer of the Purchaser (or another authorized official of the Purchaser designated by notice to the Seller in writing) for further consideration and attempted resolution within thirty (30) Days after the Dispute has been referred to such individuals (or such longer period as the Parties may agree).

21.2 Referral to an Expert

- 21.2.1 If the Dispute cannot be settled within the period allowed in Clause 21.1, either Party may upon written notice to the other Party refer the Dispute to an expert for determination, the notice shall propose an expert from a list of experts and the other Party shall confirm the proposed expert or choose from the list of experts proposed as the case may be, or object to the proposed expert or list of experts, giving reasons for the objection and proposing an alternative expert instead.
- 21.2.2 In the event that the Parties are unable within fifteen (15)Days to agree upon an expert to be appointed hereunder or upon the terms of such expert's reference or both, then either Party may request the ICC International Centre for ADR to make an appointment and such party shall do so in accordance with the Rules for the Appointment of Experts and Neutrals of the International Chambers of Commerce:
- 21.2.3 If the Respondent fails to give the Notice of Intention to Defend to the Applicant in accordance with Clause 21.2.3 **Error! Reference source not found.:**
- 21.2.3.1 the terms of reference set out in the Notice of Intention to Refer shall be adopted, incorporating where applicable and not inconsistent, the terms of this Clause 21.2.3.1
- 21.2.3.2 the Applicant may request that an expert be appointed by following the procedure set out in Clause 21.2.2.
- 21.2.4 Notwithstanding any other provision of this Clause 21, no expert appointed pursuant to this Clause 21.2 shall be a national of the jurisdiction of either Party to this Agreement or of the jurisdiction of any of the Initial Shareholders (nor shall such expert be a former employee or agent of any such person).
- 21.2.5 Within thirty (30) Days of the appointment of the expert, the expert shall nominate a time and place [NEUTRAL GROUND] for a hearing of the

- Parties on the Dispute, which time shall not be more than thirty (30) Days after the expert's appointment.
- 21.2.6 The Parties shall not be entitled to apply for discovery of documents but shall be entitled to have access to the other Party's records and data in accordance with Clause 9.11.3.
- 21.2.7 At the time nominated for the hearing, each Party must appear before the expert and present its case in accordance with the ICC Rules for the Administration of Expert Proceedings.
- 21.2.8 The expert must render his decision on the Dispute within thirty (30) days after completion of the hearing and must forthwith advise the Parties in writing of his determination and his reasons thereof.
- 21.2.9 The proceedings shall be without prejudice and any evidence given or statements made in the course of the hearing may not be used against a Party in any other proceedings.
- 21.2.10 The proceedings shall not be regarded as an arbitration and the laws relating to commercial arbitrations shall not apply; provided, however, that the expert shall resolve the Dispute in accordance with the Laws of Tanzania.
- 21.2.11 Once a Dispute is referred to an expert, the expert may shorten any of the time periods required by this Clause 21.2 if, in the expert's best judgment, the Dispute requires expeditious resolution.
- 21.2.12 The decision of the expert shall be final and binding upon both Parties upon the delivery to them of the expert's written determination, save in the event of fraud, collusion, partiality, material departure from instruction.
- 21.2.13 If the expert does not render a decision within a period of thirty (30) Days of his appointment or such longer or shorter period as the Parties may agree in writing, either Party may, upon giving notice to the other, terminate such appointment, and a new expert shall be appointed who shall resolve the Dispute in accordance with the provisions of this Clause 21.2. If the Dispute is not resolved by one or more experts within three (3) Months after the receipt by the Respondent of the Notice of Intention to Refer, then either Party may refer the Dispute for arbitration in accordance with this Agreement.
- 21.2.14 The costs of engaging an expert shall be borne equally by the Parties, irrespective of whether the Respondent engages in the process, and each Party shall bear its own costs in preparing materials for, and making presentations to, the expert.

21.3 Arbitration

- 21.3.1 Any Dispute arising out of or in connection with this Agreement that has not been resolved following the procedures set forth in Clauses 21.1 and 21.2 shall (regardless of the nature of the Dispute but without prejudice to the provisions of this Agreement requiring any matter to be referred to an expert for final determination) be referred to arbitration and finally settled in accordance with [the Convention on the Settlement of Investment Disputes between States and Nationals of other States (the "**Convention**") and the Rules of Procedure for Arbitration Proceedings of the International Centre for Settlement of Investment Disputes ("**ICSID**") established by the Convention]/[United Nations Commission on International Trade Law ("**UNCITRAL Rules**")/the International Chamber of Commerce ("**ICC Rules**") ["/[Rules of the London Court of International Arbitration ("**LCIA Rules**") which LCIA Rules are deemed incorporated into this Agreement] and the Parties hereby consent to arbitration thereunder.
- 21.3.2 The arbitral tribunal shall be composed of three arbitrators appointed as follows:
- 21.3.2.1 each Party shall nominate one arbitrator, and the two arbitrators so appointed shall appoint a third arbitrator who shall act as president of the tribunal;
- 21.3.2.2 if either Party fails to nominate an arbitrator within thirty (30) Days of receiving written notice of a request for arbitration and the nomination of an arbitrator by the other Party, such arbitrator shall at the request of that Party be appointed by the [INSERT APPROPRIATE OFFICE]; and
- 21.3.2.3 if the two arbitrators to be nominated by the Parties fail to agree upon a third arbitrator within thirty (30) Days of the appointment of the second arbitrator, the third arbitrator shall be appointed in accordance with the Arbitration Rules at the written request of either Party.
- 21.3.3 No arbitrator appointed pursuant to Clause 21.3.2 shall be a national of the jurisdiction of either Party to this Agreement or of the jurisdiction of any of the Initial Shareholders (nor shall any such arbitrator be an employee or agent or former employee or agent of any such person).
- 21.3.4 The place of the arbitration shall be [in Dar es Salaam and any other place mutually agreed by the Parties and the language of the arbitration shall be English. The Seat of Arbitration shall be mutually agreed by the parties.
- 21.3.5 The Parties undertake as a general principle to keep confidential all awards and orders in the arbitration, as well as all materials created for the purpose of the arbitration and documents produced by another party in the arbitration not otherwise in the public domain, save and to the extent that a disclosure may be required of a Party by legal duty, to protect or pursue a

legal right or to enforce or challenge an award in bona fide legal proceedings before a state court or other judicial authority.

21.3.6 Each Party hereby agrees to be bound by any final decision or award of any arbitrators duly appointed under this Agreement.

21.3.7 Except as awarded by the arbitrators, each Party shall be responsible for its own costs incurred by it in connection with an arbitration hereunder.

21.4 **Waiver of Immunity**

21.4.1 Each Party irrevocably and unconditionally acknowledges and agrees that the execution, delivery and performance by it of this Agreement constitutes a commercial act. Accordingly, each Party irrevocably and unconditionally agrees that it shall not assert any right to immunity (either present or future, existing in any jurisdiction) on behalf of itself or its assets, its revenues or its property (other than the Excepted Assets) in connection with any proceedings arising out of or in connection with this Agreement (including any arbitration under Clause 22 (Resolution of Disputes)). Each Party consents generally to the making, enforcement or execution (by attachment or otherwise) of any order, judgment or award against it or any of its assets, its revenues or its property (other than the Excepted Assets) in any jurisdiction and to the giving of any relief or the issue of any process in connection with such proceedings, whether before or after final judgment or arbitral award.

21.4.2 In this Clause, "Excepted Assets" means:

- a) property, including any bank account, which is used in the performance of the functions of the diplomatic mission of the State or its consular posts, special missions, missions to international organisations or delegations to organs of international organisations or to international conferences;
- b) property of a military character or used in the performance of military functions;
- c) property of the central bank or other monetary authority of the State;
- d) property forming part of the cultural heritage of the State or part of its archives and not placed or intended to be placed on sale;
- e) property forming part of an exhibition of objects of scientific, cultural or historical interest and not placed or intended to be placed on sale;
- f) all other assets not used for Government commercial purposes;

- g) all natural resources of a state in their natural form within the natural environment of that state;
- h) real property used in provision of public health, a public utility or any social service of a state (including, to the extent that they constitute non-commercial assets, the Tanzanian National Geothermal Infrastructure – NNGI);
- i) any Aircraft, components and parts of aircraft owned by the Government of the United Republic of Tanzania or its Agencies;
- j) any ports, harbours, port infrastructure or facilities, including quays, jetties, terminals, breakwaters, navigational channels, docks, wharves and related installations, owned, operated or controlled by the Government of the United Republic of Tanzania or any of its Agencies;
- k) power generation, transmission and distribution assets owned by the Government of the United Republic of Tanzania or its Agencies; and
- l) Railway rolling stocks assets owned by the Government of the United Republic of Tanzania or its Agencies.

21.5 Continued Performance

During the pendency of any Dispute being handled in accordance with this Clause 21:

- 21.5.1 the Seller shall continue to perform its obligations under this Agreement to deliver Dependable Capacity and Net Energy Output;
- 21.5.2 the Purchaser shall continue to pay all amounts due in accordance with Clause 9 that are not in dispute; and
- 21.5.3 neither Party shall exercise any other remedies hereunder arising by virtue of the matters in dispute.

22. ASSIGNMENT

22.1 Right to Assignment

Other than by way of the Project Documents, a Party may not assign or otherwise transfer any of its rights or obligations or subcontract or delegate in whole or in part the performance of any of its obligations under this Agreement to any person without the prior written consent of the other Parties. If written consent is given for any assignment, the assignor shall remain jointly and severally liable with the assignee for the full performance of the assignor's obligations under this Agreement, unless the Parties otherwise agree in writing. Any prohibited assignment in violation of this Clause 22.1 shall be null and void *ab initio* and the non-assigning Party shall have the right, without prejudice to any other rights or remedies it may have hereunder or

otherwise, to terminate this Agreement effective immediately upon notice to the Party attempting such assignment.

22.2 Creation of Security

- 22.2.1 Notwithstanding the provisions of Clause 22.1, for the purpose of financing the construction, operation and maintenance of the Plant, the Seller may assign or create security over its rights and interests under, pursuant to or associated with the assets identified in Clause 22.1; except that the Seller shall not create any such security without the prior written consent of the Purchaser/GoT.
- 22.2.2 The Purchaser shall execute all such acknowledgments of any security created in accordance with Clause 22.2.1 above as are reasonably requested by the Seller to give effect to the security.
- 22.2.3 The Purchaser shall use all reasonable efforts to execute, acknowledge and deliver any and all further documents and instruments, and to take any other actions, which may be necessary to satisfy the reasonable requests of any Finance Parties or prospective Finance Parties in connection with the financing or refinancing of the Project, including executing and delivering to the Finance Parties a consent to assignment (or other form of direct agreement) concerning the Project between the Purchaser and the Finance Parties in form and substance satisfactory to the Finance Parties.
- 22.2.4 Nothing in Clause 22.2.3 shall be construed to require the Purchaser to execute, acknowledge and deliver any further documents and instruments, or to take any other actions, which are inconsistent with its rights under this Agreement or which are expressly subject to its consent or approval under this Agreement.

23. NOTICES

23.1 Address for Notices

- 23.1.1 The Parties shall give each other notice or other communication under this Agreement in writing in English and, unless otherwise provided, by fax or letter. Any notice or communication given by one Party to another under this Agreement shall (unless one Party has by five Days' notice to the other Party given another address) be given to that other Party at the respective address below:

Purchaser:

Address: _____

Attention: _____

Facsimile No.: _____

Email: _____

Seller:

Address: _____

Attention:

Facsimile No.: _____

Email: _____

23.1.2 Any notice or other communication given by a Party is deemed to have been received:

23.1.2.1 if sent by fax, with a confirmed receipt of transmission from the receiving machine on the Day it was transmitted;

23.1.2.2 if sent by email, with a confirmed acknowledgement of receipt and read of transmission from the receiving device on the Day it was transmitted;

23.1.2.3 in the case of a notice given by hand, on the Day of actual delivery;

23.1.2.4 if posted, on the [fifth] Business Day following the Day it was posted by first class mail postage prepaid, on condition that a notice given but received on a Day which is not a Business Day or after normal business hours is deemed to have been received on the next Business Day.

23.2 Address for Service

The Purchaser's address for service is and any claim forms, application notices, judgment orders or other notices of legal process relating to the Agreement may be served on [the Purchaser] by hand delivery or posting it by pre-paid first class recorded delivery post to:

1. the address for service given in this Clause; or
2. another address for service in [Tanzania] notified to GoT in writing by the Purchaser.

24. MISCELLANEOUS

24.1 Variations in Writing

This Agreement may not be altered, amended, modified or otherwise changed in any respect except in writing duly executed by each Party.

24.2 Entire Agreement

This Agreement and all Schedules thereto together represent the entire understanding between the Parties in relation to the subject matter thereof and supersede any or all previous agreements or arrangements between the Parties in respect of the Plant (whether oral or written). The Parties confirm that they have not entered into this Agreement on the basis of any representation that is not expressly incorporated into this Agreement (or the documents referred to in it).

24.3 Waiver

24.3.1 A waiver of any right or remedy under this Agreement or by law is only effective if given in writing and shall not be deemed a waiver of any subsequent breach or default.

24.3.2 No failure or delay by the Purchaser in exercising any right or remedy under this Agreement shall constitute a waiver of such right or remedy and no waiver of any breach by the Seller of this Agreement shall be deemed to be a waiver of any other breach. No single or partial exercise of any right or remedy by the Purchaser under this Agreement shall preclude or restrict the further exercise of any such right or remedy.

24.4 Severability

If any provision or part-provision of this Agreement is or becomes invalid, illegal or unenforceable, it shall be deemed modified to the minimum extent necessary to make it valid, legal and enforceable. If such modification is not possible, the relevant provision or part-provision shall be deemed deleted. Any modification to or deletion of a provision or part-provision under this Clause shall not affect the validity and enforceability of the rest of this agreement.

24.5 Counterparts

The Parties may execute this Agreement in any number of counterparts and this shall have the same effect as if the signatures on the counterparts were on a single copy of this Agreement.

24.6 Confidential Information

Each Party shall keep confidential any information whether written or oral, concerning the other Party or their directors, officers or employees, or the Project, which that Party shall receive from the other Party and which is marked (if the information is delivered in written form) or otherwise designated as or indicated to be "confidential" at the time of disclosure or which must be understood to be confidential by reason of the circumstances applicable to its disclosure ("**Confidential Information**") and shall not divulge the same to any third party (save insofar as may be necessary for the purpose of carrying out this Agreement) and save in respect of disclosure:

24.6.1 to any Party's professional advisers or the Construction Contractors;

- 24.6.2 to the extent required by Law;
- 24.6.3 to any Government Authority lawfully requesting such information;
- 24.6.4 to any court of competent jurisdiction acting in pursuance of its powers; or
- 24.6.5 if it was or is in the public domain other than through its fault or the fault of any person to whom such Confidential Information has been disclosed as permitted by this Clause 24.6.

24.7 Survival

- 24.7.1 The provisions of Clauses 12.3.6, 12.4, 12.6, 14, 21, 21, 23, 24.6, 24.7, 24.8, 24.12 and 24.15 shall survive the expiry, cancellation or termination of this Agreement (however arising) and shall continue in full force and effect until all of the Parties' obligations and liabilities under them have been performed and discharged in full.
- 24.7.2 Without prejudice to the generality of this Clause 24.7, the cancellation, expiry or termination of this Agreement or any arbitration of disputes shall not relieve the Parties of obligations that by their nature should survive such cancellation, expiration or termination, including warranties, remedies, promises of indemnity and confidentiality.

24.8 Relationship of the Parties

This Agreement shall not be interpreted or construed to create an association, joint venture, partnership or agency between the Parties or to impose any partnership obligation or liability upon any Party. No Party shall have any right, power or authority to enter into any agreement or undertaking for, or act on behalf of, or to act as or to be an agent or representative of, or to otherwise bind, the other Parties. The Purchaser shall be solely responsible for the payment of salaries, wages and mandatory fringe benefits of its employees, which will not have any relationship of any kind with GoT.

24.9 Successors and Assigns

This Agreement shall inure to the benefit of, and be binding upon, the Parties hereto and their respective successors and permitted assigns.

24.10 No Liability for Review

No review or approval by the Purchaser of any agreement, document, instrument, drawing, specifications or design proposed by the Seller shall relieve the Seller from any liability that it would otherwise have had for its negligence in the preparation of such agreement, document, instrument, drawing, specifications or design or from failure to comply with the applicable Laws of Tanzania with respect thereto, nor shall the Purchaser be liable to the Seller or any other person by reason of its review or approval of an agreement, document, instrument, drawing, specification, or design. Furthermore, the Purchaser shall not be liable to the Seller or any other person by

reason of its observation or inspection of, or any suggestions relating to, the construction, testing, operation or maintenance of the Plant.

24.11 Affirmation

The Seller and the Purchaser declare and affirm that neither Party has paid nor has it undertaken to pay and that it shall in the future not pay any bribe, pay-offs, kick-backs or unlawful commission and that it has not in any other way or manner paid any sums, whether in Local Currency or Foreign Currency and whether in Tanzania or abroad, or in any other manner given or offered to give any gifts and presents in Tanzania or abroad to any person or company to procure this Agreement, and the Seller and the Purchaser undertake not to engage in any of the said or similar acts during the term of and relative to this Agreement. the Seller and the Purchaser declare and affirm that neither Party is in breach of the provisions related to good conduct as set out in the provisions of (i) [the United States Foreign Corrupt Practices Act] (ii) [the UK Bribery Act] and (iii) [other sanctioning regimes as applicable; (iv) [Prevention and Combating Corruption Act].

24.12 Consequential Damages

Neither Party shall be liable to the other Party in contract, tort, warranty, strict liability or any other legal theory for indirect, consequential, punitive or exemplary damages resulting from the performance of obligations or the exercise of rights under or pursuant to this Agreement.

24.13 No Third-Party Beneficiaries

This Agreement is intended solely for the benefit of the Parties hereto and, except for rights expressly granted to the Finance Parties or other persons, nothing in this Agreement shall be construed to create any duty to, standard of care with reference to, any liability to, or any right of suit or action in, any person not a Party to this Agreement.

24.14 Governing Law

This Agreement and any dispute or claim arising out of or in connection with it or its formation (including non-contractual disputes or claims) shall be governed by, and construed in accordance with, the Laws of Tanzania.

24.15 Language

The language of this Agreement shall be English. All documents, notices, waivers and all other communications written or otherwise between the Parties in connection with this Agreement shall be in English.

IN WITNESS whereof the Parties have entered into this Agreement the date first above written.

Signed by [] duly authorised)
for and on behalf of [PURCHASER]:)
)

Signature _____

Name (block capitals) _____

Before [])
)
)

Signature _____

Name (block capitals) _____

Date: _____

Signed by [] duly authorised)
for and on behalf of [SELLER]:)
)

Signature _____

Name (block capitals) _____

Before []

Signature _____

Name (block capitals) _____

Date:

Schedule 1 - Project-Specific Terms, Minimum Functional, and Fuel Specifications

The following is an example of the form that Schedule 1 may take. It is not intended to be prescriptive.

Part 1: Project-specific definitions:

Base Rate:

Fuel: [SPECIFY GEOTHERMAL AND THE SOURCE OF GEOTHERMAL]

Margin:

- Project Documents:**
- Implementation Agreement
 - Construction Contract
 - All Permits
 - O&M Contract
 - Fuel Supply Agreement
 - Any agreements with Direct Contractors
 - Any other Original Project Document or Amended Project Document
 -

Required Commercial Operations Date:

Target CP Satisfaction Date:

Contracted Dependable Capacity:

Open Cycle Operation:

Combined Cycle Operation: [Agreed/Not Agreed]

Two Step Operation:

Part 2: Plant Characteristics

A. Turbine (Type, Capacity) [Type] MW

B. Generator

1 Rated capacity MVA

2 Rated voltage kV

3 Rated frequency 50 Hz

4 Power Factor

5 Operating voltage kV

6 Stator winding connection Star

7 Efficiency at rated capacity, voltage and p.f.

8 Short circuit current kA

9 Insulation class/Temperature rise

10 Enclosure

11 Standard IEC 34

1. The alternator voltage and frequency variation during operation will be in accordance with IEC 60034-1
2. PQ diagram is depicted in Annex A to this First Schedule. The Facility shall be capable of operating within the normal operating limits and the short-term tolerance limits set out under Transmission Specifications. The Facility shall also be capable of tolerating Purchasers power system fault level set out under Transmission Specifications.

C. Generator Switchgear

[]

D. Protection Schemes

1. Earth fault protection
2. Differential protection
3. Over Voltage Protection
4. Reverse Power Protection
5. Over current and short circuit protection
6. Loss of excitation protection

E. Step-up Transformer

[]

F. Supply of Reactive Power

The Plant should be capable of delivering Active Power equal to the Contracted Dependable Capacity at a power factor of 0.85 lagging in order to supply Reactive Power when the Purchaser demands.

G. Spinning Reserve

The Plant should be capable of operating at part load in both modes Open Cycle Operation and Combined Cycle Operation with governor control.

Fuel Component of the Energy Charge for part load operation will be determined according to Schedule 5 -.

H. Protection System

The Seller will install necessary current limiting devices such as thyristors etc. if required. The Seller shall provide protection system in compliance to Grid Code requirement for short circuit level, neutral grounding, current unbalance, limiting of harmonics, fault clearing time etc. as per data provided by the Purchaser under the interconnection study.

Part 3: Transmission Specifications

7. **System fault level: [] MVA**
8. **Voltage and Frequency Limitations**

Grid Variation Limits of Voltage at 33 kV, 132 kV, 220kV or 400kV as applicable, and Frequency

Normal operation limits

Voltage

Nominal 33kV

Variation 33 kV $\pm 6\%$

Nominal 132kV

Variation 132 kV $\pm 10\%$

Nominal 220kV

Variation 220 kV $\pm 10\%$

Nominal 400kV

Variation 400 kV $\pm 10\%$

Frequency

Nominal 50 Hz

Variation $\pm 1\%$

Short-term variations

Voltage

33kV +6% -10% up to 5 sec.

132kV +6% -10% up to 5 sec.

220 kV +6% -10% up to 5 sec.

400 kV +6% -10% up to 5 sec.

Machine characteristics to IEC 60034-1

9. Under-frequency operation

9.1 Under frequency relay setting shall be set by the Purchaser at 47 Hz delayed by 250 ms. Machine under frequency shall be set by the Seller at 47 Hz delayed in excess of 2 sec to trip.

Schedule 1 -may also include:

Grid and other Electric Equipment Requirements;

Site Conditions; and
Facilities Descriptions and Design Data.
Fuel Specifications
Heat rate Curves already included below

Annex A: P – Q Diagram of the Generator

Annex B: Turbine Ramp Time Schedule

Annex C: Heat Rate Table for the Open Cycle Operation

Load Level (= L)	Heat Rate (kJ/kWh)
L = 50%	[]
50% < L ≤ 55%	[]
55% < L ≤ 60%	[]
60% < L ≤ 65%	[]
65% < L ≤ 70%	[]
70% < L ≤ 75%	[]
75% < L ≤ 80%	[]
80% < L ≤ 85%	[]
85% < L ≤ 90%	[]
90% < L ≤ 95%	[]
95% < L ≤ 100%	[]

Annex D: Heat Rate Table for Combined Cycle Operation

Load Level (= L)	Heat Rate (kJ/kWh)
L = 50%	[]
50% < L ≤ 55%	[]
55% < L ≤ 60%	[]
60% < L ≤ 65%	[]
65% < L ≤ 70%	[]
70% < L ≤ 75%	[]
75% < L ≤ 80%	[]
80% < L ≤ 85%	[]
85% < L ≤ 90%	[]
90% < L ≤ 95%	[]
95% < L ≤ 100%	[]

Schedule 2 - Interconnection Facilities

- **Clause Error! Reference source not found. foresees that the Purchaser and Seller shall design, construct, install, commission, operate and maintain respective sides of Interconnection Facilities.**
- **In the event that the Purchaser takes on the responsibilities as set out in Clause Error! Reference source not found. it is recommended to limit the Purchaser's liability for any delays in designing, constructing, and operating the Interconnection Facilities (see suggested aggregate cap on liability in Clause Error! Reference source not found.).**
- **The definition of Interconnection Facilities refers to this Schedule 2 - which should contain the necessary technical details of the Interconnection Facilities as agreed between the parties taking into account the existing infrastructure.**
- **Clause Error! Reference source not found. sets out the responsibilities of the Seller with regard to the Interconnection Facilities in general terms.**
- **In accordance with Clause Error! Reference source not found. the parties may agree on procedures related to the testing of the Interconnection Facilities as appropriate (see also testing procedures in Schedule 3 -).**

[Single Line Diagram of Interconnection Facilities showing equipment connected, Point of Interconnection, Metering Point and Point of Supply, see sample below]

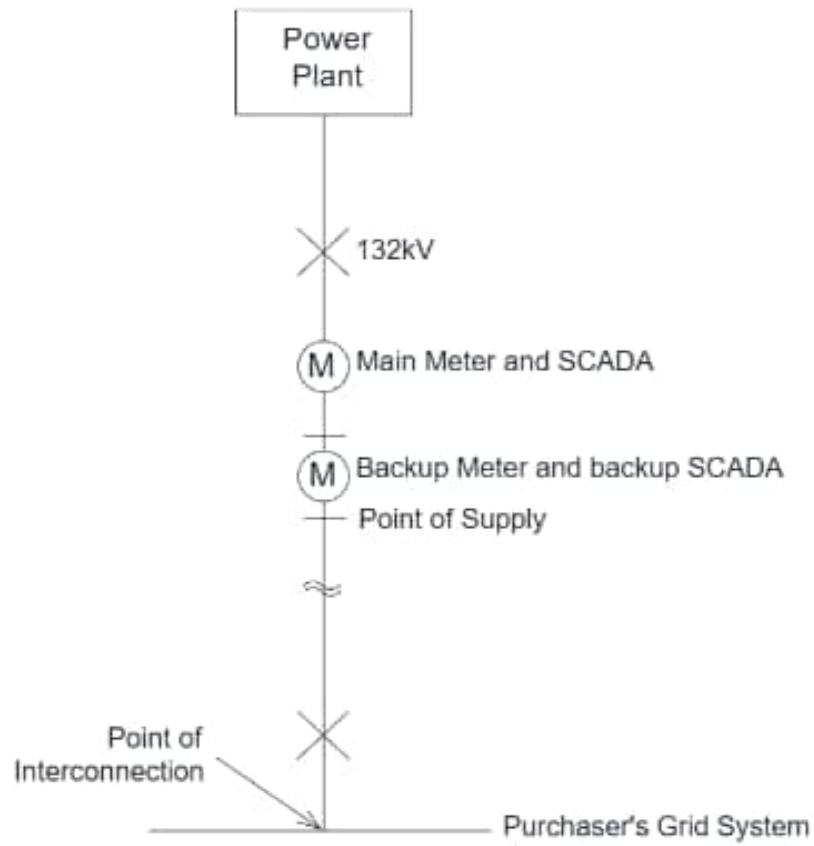

Schedule 3 - Testing and Commissioning

Commissioning means the operations required for testing of the Plant and will be further defined in this schedule.

The Seller's responsibilities with regard to testing are determined by Clause 9.13.2 and this Schedule 3 -. In accordance with Clause 9.13.2 the Seller is responsible for the testing of

- **the Dependable Capacity of the Plant following the Commissioning of the Plant;**
- **an additional test of Dependable Capacity if Commissioning of the Plant indicates that there will be a Commissioned Shortfall; and**
- **periodic [(annual)] tests in accordance with an agreed testing schedule (Clause 10.1 in combination with Clause 10.4) which may be amended or substituted in this Schedule 3 -.**

This schedule is subject to technical input and should include a description of as to how the tests will be carried out as well as the timing for the periodic tests.

It is recommended to pre-agree and standardize the testing and the way test results will be recorded, as well as the frequency and timing of testing. The procedures below may not be applicable depending on the project but have been inserted in order to provide an example for possible testing procedures/protocols (Please note that the following contains a number of definitions which should be integrated into Clause 1 of the Agreement if the procedures below will be adopted):

1. Objective

- 1.1. The objective of the Dependable Capacity test is to determine the sustained capacity of the Plant.
- 1.2. The testing procedures below detail the test set-up, the test instrumentation and measurements, the test preparations, and the operational conditions to be used. It also presents the evaluation methodology by which results are to be determined.
- 1.3. Changes to this procedure may be made only with the written consent of the Test Representatives as defined below) of both the Seller and Purchaser.
- 1.4. [Add any other requirements depending on the technical set-up of the Plant.]

2. Test codes and other relevant standards

[Parties to agree on test codes or other standards relevant to the testing and applicable to the Plant including without limitation SHE standards.]

3. Seller's Responsibilities

- 3.1. The Seller shall comply with the pre-agreed Commissioning schedule. In the event of any changes to the Commissioning schedule, the Seller shall inform Purchaser about any such changes giving reasonable notice.
- 3.2. Not later than [] Days prior to the scheduled date for the test, the Parties shall agree upon an Independent Engineer, who shall witness the testing. Test Representatives shall ensure that the Engineer shall have complete access to information applicable to

- the conduct of the test. This information includes, but is not limited to, [proposed test procedure, the instrument calibration records for the test, observation of unit operation, data acquisition, and the test log - add other criteria depending on the type of installation/plant.]
- 3.3. The Seller shall carry out the tasks related to the Commissioning as set out in this test procedures and shall ensure that the Independent Engineer is present during Commissioning. The Parties shall agree upon, in writing, reasonable changes to the test procedure provided herein due to unforeseen circumstances.
 - 3.4. The Seller shall ensure that the Independent Engineer shall have the full and unrestricted opportunity to examine the Plant and all machinery prior to, during, and after each test run. The Independent Engineer shall have the opportunity to conduct preliminary testing to determine the need for re-calibration, cleaning, or other adjustments for measuring instruments.
 - 3.5. The Seller shall be responsible for directing operation of the Plant during performance testing, including supervision of operating and maintenance personnel in the operation of all equipment associated with the Plant.
 - 3.6. The Seller shall nominate and notify to the Purchaser a test director ("Test Director") to oversee all tests leading up to and including the testing. The Test Director shall ensure that each test is conducted in accordance with the relevant test procedure. The Test Director shall be present during all tests. The Independent Engineer should direct questions and concerns to the Test Director.
 - 3.7. [The Test Director shall issue formal 30-day and 7-day test notifications to the Purchaser and to the Independent Engineer and shall keep the Purchaser and the Independent engineer informed of test activities and progress.]
 - 3.8. [The Seller shall provide all calibrated test class instrumentation and certification.]
 - 3.9. Immediately after each test run, the Seller shall collect all performance test data, obtain all required signatures, and make copies for the Purchaser and the engineer.
 - 3.10. The Seller shall submit to the Purchaser and the Independent Engineer a letter providing preliminary corrected test results as per the Reports section of this test procedure.
 - 3.11. The Seller shall prepare and submit to Purchaser and the Independent Engineer a detailed test report ("Test Report") providing final test results in accordance with this test procedure, which shall be countersigned and certified by the Independent Engineer if the engineer has concluded that the testing has been carried out in accordance with this Agreement and this Schedule [] and agrees with the Test Report and concurs with its conclusions.
 - 3.12. The Seller shall calibrate all instruments and provide to Purchaser and the Independent Engineer [testing] instrument calibration certificates.
 - 3.13. [The Seller is responsible for providing fuel, water and all other consumables necessary to carry out the test program. the Seller shall provide at its cost and expense reasonable accommodation and meals for Independent Engineer on Site so as to permit them to remain on Site during the continuation of all testing.]
 - 3.14. [The Seller is responsible for providing all manufacturers generated correction curves

to the Purchaser and to the Independent Engineer.]

4. Preparation - General

- 4.1. All safety devices, protective relays, support systems [, add other information as appropriate] shall be checked and confirmed to be operational before testing. All protective equipment shall be in service and operating, unless a specific protection feature must be disabled to demonstrate an operational limit. The Plant equipment shall be operated in accordance with manufacturer's operating guidelines.
- 4.2. [Manufacturer's recommended operating procedures and instructions must be followed.]

5. Test Log

- 5.1. The Test Director shall keep a test log ("Test Log") for recording significant events and notes. The information in the Test Log shall be available to the Purchaser and the Independent Engineer at any time. A copy of the Test Log shall become part of the test report.

6. Test Set-Up, Measurements and Instrumentation

- 6.1. The test set-up consists of [specify depending on Plant].
- 6.2. The parameters to be measured include, but are not limited to: [specify depending on Plant].
- 6.3. [Add additional parameters and testing requirements as appropriate.]

7. Test Preparation

- 7.1. The Test Director shall confirm the calibration and proper operation of all instruments and recording systems to be used for the test.
- 7.2. [Specify additional requirements that should be added depending on the Plant.]
- 7.3. The Test Director shall give notice of test readiness to the Purchaser and the Engineer.
- 7.4. [The Test Director will meet with data takers and delegate assignments and distribute blank data sheets.]

8. Conduct of the Test - general

- 8.1. [Specify Plant specific requirements related to the testing.]

9. Corrections to data and calculation results

- 9.1. [Parties to agree methods of correcting the data and calculation results.]

10. Test Report

- 10.1. A preliminary test report for the Dependable Capacity shall be issued within [24 hours] after the conclusion of the test.
- 10.2. The preliminary report of Dependable Capacity shall be based on test data and shall include preliminary results and a short discussion.
- 10.3. A final report on the Dependable Capacity shall be issued within [10 Days] of the completion of the test.
- 10.4. The Dependable Capacity contained in the preliminary report shall be applicable for purposes of the Power Purchase Agreement until the earlier of [ten (10) Days] from

its issue by the Independent Engineer and the issuance of the final report of Dependable Capacity as approved and certified by the Independent Engineer.

10.5. The final report shall include, as a minimum, the following sections:

- Description of the test, arrangements, equipment, instruments and their location and operating conditions;
- Summary of relevant measurements and observations;
- Calculation methodology;
- Calibration curves of instruments and apparatus used in the test;
- Correction factors to be applied because of deviations, if any, from Guarantee Conditions;
- Results [parameters depending on the Plant].

Schedule 4 - Metering and Telecommunications

- **The metering and the use of telecommunication equipment are set out in detail in Clause 8 of the Agreement.**
- **This schedule should contain a list or description of the equipment used and potentially testing schedules and procedures.**
- **The Parties may want to include the testing procedures set out in Schedule 3 - to the extent that these do not differ from the provisions in Clause 8.**

Location of Meters

The metering points to record the kW and kWh exchange between the Plant and the Purchaser's system shall be located as depicted in Schedule 2 - and shall utilise current and voltage transformers. Both the Main Meter and the Back-up Meter shall be installed in a separate room or cabinet and shall only be accessed by the Purchaser and Seller as prescribed in Clause 8 of this Agreement

Specification of Meters

Type	Precision Accuracy Type Poly-phase Energy Meters
Standard	IEC 62052-11 and IEC 62053-22
Current rating	1 A
Accuracy class	0.2
Measurement range	20 – 100% of rated current
Burden	3.2 VA
Rated voltage	16.5/√3 V
Measure range	90 to 110 % of the rated voltage

The Meters shall be capable of constantly recording and storing the power delivered by the Facility over any period of time in kW.

Specifications of Current Transformers

Standard	IEC 61869-1 and IEC 61869-2
Number of phases	Single
Location	Outdoor
Highest system voltage	36 kV/145 kV (as applicable)
Rated system voltage	33 kV/132 kV (as applicable)
Rated frequency	50 Hz
Burden	15VA
Transformer cores	(i) Class 5P20, Ratio: (...) / 1A for over current and earth fault protection. (ii) Class 0.2P20, Ratio: (...) / 1A for metering

Specifications of Voltage Transformers

Standard	IEC 61869-1 and IEC 61869-3
----------	-----------------------------

Type	Capacitor/Wound
Burden per phase	15VA
Location	Outdoor
Highest system voltage	[] kV/[] kV (as applicable)
Rated system voltage	[] kV/[] kV (as applicable)
Rated frequency	50 Hz
Maximum Ratio error	± 1 % (as per IEC 186, Clause 25)
Maximum phase angle error	40 Min/1.2 Centi-radians (as per IEC 186, Clause 25)
Voltage Ratio	132,000/√3 or 33,000/√3 (as applicable) : 110/√3 : 110/√3 : 110/√3 V
Accuracy Class	0.2P20

Specification of Remote Terminal Units

Schedule 5 - Payments [, Indexation and Adjustment - if applicable]

Below is an example of a payment mechanism that is appropriate for geothermal-fired power projects. It is not intended to be prescriptive. Any changes in this Schedule may however result in changes in the main body of the Agreement being required.

The Parties will record the following prices/payments in this schedule:

- Capacity Charge
- Energy Charge
- Deemed energy charges due to the Purchaser's inability to off-take power from the Seller, as determined by the Parties,
- Payments for Ancillary Services if payable by the Seller

In addition, the Parties may agree on adjustments to the payments/prices payable by linking the price to consumer or producer price indices in Tanzania, which may be recorded in this schedule.

The Tariff for the supply of electricity to the Purchaser comprises of the Capacity Charge, and the Energy Charge. The above components of the Tariff, except for the Non-Escalable component of the Capacity Charge, are based upon prices as of [Month and Year] and, accordingly, will vary over the Term of the Agreement. The Tariff is based on the Contracted Dependable Capacity declared. The escalation of the components will be calculated according to the method and indexation described below. Non-Escalable component of the Capacity Charge is fixed and shall not be subject to escalation.

For purpose of calculating various components of the Tariff, the indices used herein shall be calculated on a semi-annual basis in the first Month and the seventh Month in each Year on the basis of the most recently available Consumer Price Index (CPI) index.

1. Capacity Payment (CP_i)

Capacity Payment for a given Month will be determined based on the Capacity Charge applicable for the month and the Contracted Dependable Capacity or Commissioned Dependable Capacity or On-going Dependable Capacity, whichever is lower.

$$CP_i = CC_i * DC$$

Where:

CP_i	Capacity Payment for the i th Month
CC_i	Capacity Charge for the i th Month
DC	Contracted Dependable Capacity or Commissioned Dependable Capacity or On-going Dependable Capacity, whichever is lower

The Capacity Charge (CC_i) for each billing period is the fixed component of the Tariff, expressed in US Dollars per MW per month. The Capacity Charge comprises the Capacity Charge (Non-Escalable Component) (CC_{net}) and the Capacity Charge (Escalable Component) (CC_{ei}) as described below.

$$CC_i = CC_{net} + CC_{ei}$$

If two step operation is agreed, the Seller shall declare Capacity Charge both escalable and non-escalable for both Open Cycle Operation and Combined Cycle Operation. Capacity Charges for Open Cycle Operation will be applicable only during the period from the Commercial Operations Date until completion of Commissioning tests on Combined Cycle Operation. Capacity Charges for Combined Cycle Operation will be applicable from the completion of Commissioning tests on Combined Cycle Operation, irrespective of whether the Plant is dispatched in Open Cycle Operation or Combined Cycle Operation.

1.1 Capacity Charge (Non-Escalable Component) : CC_{net}

The Capacity Charge (Non-Escalable Component) reflects, in part, the debt servicing obligations of the Seller. Accordingly, the Capacity Charge (Non-Escalable Component) set forth herein is based on certain assumptions relating to interest rates, repayment terms and grace periods applicable to the Seller's debt financing which are set forth in the financial model attached hereto as Annex A2 and incorporated herein by reference. The Capacity Charge (Non-Escalable Component) for each respective year, payable over the Term, expressed in US Dollars per MW per month is provided in **Annex G** hereto.

The Capacity Charge (Non-Escalable Component) shall be adjusted on the Target CP Satisfaction Date to reflect the SOFR (applicable for one-year debt) and the actual spread applied to the interest rate of the debt raised by the Seller, subject to a maximum spread of [] Such adjustments to the Capacity Charge (Non-Escalable Component) will be determined by only adjusting the model in Annex A2 to reflect the changes in the rates of SOFR (applicable for one-year debt) and the actual spread applied to the interest rates of the debt raised by the Seller, while keeping all the other parameters of the model in Annex A2 constant. For the avoidance of doubt, changes in SOFR and spread will result in changes of Annex A2 under the headings of interest, interest during construction, working capital, financing costs and the total project cost.

For the purpose of calculating the interest rates under this paragraph, the Seller shall provide Purchaser the extracts from the relevant Financing Agreements, quotations for swap in the event that the Seller had not made itself available of a swap by the Target CP Satisfaction Date or such other supporting documentation as the Purchaser may reasonably require.

1.2 Capacity Charge (Escalable Component): CC_{ei}

The Capacity Charge (Escalable Component) covers all administration costs, fixed operation and maintenance fees, and related expenses. It has the base values expressed in US Dollars

per MW per month, as given in **Annex G** hereto. CC_{it} shall have the values expressed in US Dollars as determined according to the following formula.

$$CC_{it} = CC_{ey} * \frac{CPI_t}{CPI_{base}}$$

Where:

CPI_t most recently available CPI in period y;
 CPI_{base} CPI in [Base month and year]
 CC_{ey} Capacity Charge (Escalable Component) as given in the **Annex G**

2. Energy Payment: EC_i

The Energy Payment (EP_i) is the energy component of the Tariff expressed in U S Dollars (US\$) (“Energy Payment”) will depend on the Net Energy Output calculated based on Plant Output Profile. The Energy Payment comprises Energy Payment (Non-fuel Component) (“ EP_{nfi} ”), Energy Payment (Fuel Component) (“ EP_{fi} ”) and Fuel Pipeline Cost (PC_i) as described below.

$$EP_i = EP_{nfi} + EP_{fi} + PC_i$$

2.1 Energy Payment (Non-fuel Component): EP_{nfi}

The Energy Payment (Non-fuel Component) (EP_{nfi}) expressed in United States Dollars is based on the Energy Charge (Non-fuel Component) (EC_{nfi}) the component of the Energy Charge which includes the variable operation and maintenance costs and the Net Energy Output. EC_{nfi} shall have the values expressed in US Dollars per kWh as determined according to the following formula.

$$EP_{nfi} = EC_{nfi} * E$$

Where:

EP_{nfi} Energy Payment (Non-fuel Component)
 EC_{nfi} Energy Charge (Non-fuel Component)
 E Net Energy Output

$$EC_{nfi} = EC_{nfy} * \frac{CPI_t}{CPI_{base}}$$

Where:

EC_{nfi} Energy Charge (Non-fuel Component) in billing period i;
 EC_{nfy} base Energy Charge (Non-fuel Component) value given in Annex F
 CPI_t most recently available USCPI in billing period i;
 CPI_{base} CPI in [Base month and year]

2.2 Energy Payment (Fuel Component): EP_{fi}

Energy Payment (Fuel Component) shall be calculated in accordance with the following formula;

$$EP_{fi} = \sum_{j=50\%}^{100\%} (EC_{fi,oc,j} * E_{ploc,j}) + \sum_{j=50\%}^{100\%} (EC_{fi,cc,j} * E_{plcc,j})$$

Where:

EP_{fi}	Energy Payment (Fuel Component)
$EC_{fi,oc,j}$	Energy Charge (Fuel Component) for the Open Cycle Operation at load level j
$EC_{fi,cc,j}$	Energy Charge (Fuel Component) for the Combined Cycle Operation at load level j
$E_{oc,j}$	Total energy output at load level j in Open Cycle Operation
$E_{cc,j}$	Total energy output at load level j in Combined Cycle Operation

2.2.1 Energy Payment (Fuel Component) for the Open Cycle Operation: $EC_{fi,oc}$

Energy Charge (Fuel Component) Open Cycle Operation shall be calculated in accordance with the following formula;

$$EC_{fi,oc,j} = HR_{oc,j} * FER_m$$

$$50\% \leq j \leq 100\%$$

Where:

$EC_{fi,oc,j}$	Energy Charge (Fuel Component) for Open Cycle Operation at load level j
$HR_{oc,j}$	Heat rate expressed in kJ/kWh for Open Cycle Operation at load level j as stated in Annex C of Schedule 1 -
FER_m	Fuel energy rate expressed in US\$/kJ as stated in Annex F of Schedule 5 -

2.2.2 Energy Charge (Fuel Component) for the Combined Cycle Operation: $EC_{fi,cc}$

Energy Charge (Fuel Component) for the Combined Cycle Operation shall be calculated in accordance with the following formula;

$$EC_{fi,cc,j} = HR_{cc,j} * FER_m$$

$$50\% \leq j \leq 100\%$$

Where:

$EC_{fi,cc,j}$	Energy Charge (Fuel Component) for the Combined Cycle Operation at load level j
$HR_{cc,j}$	Heat rate expressed in kJ/kWh for combined cycle operation at load level j as stated in Annex D of Schedule 1 -
FER_m	Fuel energy rate expressed in US\$/kJ as stated in Annex F of Schedule 5 -

2.3 Fuel Pipeline Cost (PC_i)

Fuel Pipeline Cost is pipeline charges for delivery of geothermal to the Plant and is a regulated price. Fuel Pipeline Cost shall be determined in accordance with the following formula;

$$PC_i = P_i \times \sum_{j=50\%}^{100\%} \sum_{k=oc}^{cc} HRI_{ijk} \times E_{ijk}$$

Where:

P_i Pipeline charge for delivery of 1kJ of geothermal to the Plant in month i

HR_{ijk} Heat Rate in kJ/kWh for load level j in oc mode or cc mode, in month i

E_{ijk} Energy delivered in load level j in oc mode or cc mode, in month i

3. Start-Up Charges

The Start-Up cost for each type of start shall be indexed partially to the Fuel Energy Rate and partially to the GCCPI in the following proportions:

$$S_m = S * \left(0.9 * \frac{FER_m}{FER_r} + 0.1 * \frac{CPI_m}{CPI_r} \right)$$

Where:

S_m is the rate of relevant immediate (S_{im}), hot (S_{hm}), warm (S_{wm}) or cold (S_{cm}) start applicable in month m; and

S is the rate of relevant immediate, hot, warm or cold start as per Annex F for Open Cycle Operation and Combined Cycle Operation, as the case may be; and

FER_r in the value of FER for the reference month [Month & Year]

A Start-Up Charge is payable for any Start-Up of the Facility solely necessitated by Dispatch instructions by the Purchaser for any Month during the Term, unless the Start-Up is required due to Forced Outages, or for Start-Up required after Scheduled Outages or Maintenance Outages and the Start-Up Charge for a given month shall be calculated in accordance with the following formula:

$$SC_m = n_{im} * S_{im} + n_{hm} * S_{hm} + n_{wm} * S_{wm} + n_{cm} * S_{cm}$$

where:

SC_m is the Start-Up Charge applicable in Month m (US\$);

n_{im} is the number of immediate re-starts in Month m, eligible for a Start-Up Charge, where "**Immediate Re-start**" means any Start-Up not more than two hours after de-synchronisation of the Plant from the Purchaser's system;

n_{hm} is the number of hot starts in Month m, eligible for Start-Up Charge, where "**Hot start**" means any start-Up not more than eight Hours after de-synchronisation of the Plant from the Purchaser's System;

- n_{wm} is the number of warm starts in Month m , eligible for a Start-Up Charge, where “**Warm Start**” means any Start-Up more than eight Hours but not more than forty-eight Hours after de-synchronisation of the Plant from the Purchaser’s system;
- n_{cm} is the number of cold starts in Month m , eligible for a Start-Up Charge, where “**Cold Start**” means any Start-Up more than forty-eight Hours after de-synchronisation of entire Plant from the Purchaser’s System (including after a major overhaul);
- S_{im} is the rate for immediate Re-starts applicable in Month m (Rs), as calculated;
- S_{hm} is the rate for Hot Start-Ups applicable in Month m (Rs), as calculated;
- S_{wm} is the rate for Warm Start-Ups applicable in Month m (Rs) as calculated; and
- S_{cm} is the rate for Cold Starts applicable in Month m (Rs) as calculated.

5. **Rounding**

All intermediate calculations to ascertain any applicable price or charge under this Schedule shall be made using a commercially available spreadsheet. Figures required for the intermediate calculation shall be to at least eight significant figures. Final monetary sums shall be rounded to the nearest United States Dollar [or Tanzanian Currency], as the case may be, using the “Round” function supplied with the spreadsheet.

Annex E: Invoice Format

Name and Address of Purchaser

For the Attention of:

Invoice No: -.....
.....

Date:

	Q'ty,	Rate	Value, US\$
Power Purchase Agreement Dated;at..... <u>On-going</u> <u>Dependable</u> <u>Capacity (MW)</u> Capacity Payment <u>Energy Sales</u> Energy Sales for the month ending/20xx (kWh) at Load Level (X) (i) 50% ≤ X < 55% (ii) 55% ≤ X < 60% (iii) 60% ≤ X < 65% (iv) 65% ≤ X < 70% (v) 70% ≤ X < 75% (vi) 75% ≤ X < 80% (vii) 80% ≤ X < 85% (viii) 85% ≤ X < 90% (ix) 90% ≤ X < 95% (x) 95% ≤ X < 100% <u>Energy Charge</u> Start –Ups <u>Immediate Start-Ups</u> <u>Hot Start-Ups</u> <u>Warm Start-Ups</u> <u>Cold Start-Ups</u> Start-Up Charge Sub Total			

Energy and Water Utilities Regulatory Authority

<u>Sales Taxes</u>			
<u>Reimbursements</u> Reimbursable Taxes			
<u>Any other (please specify)</u>			
<u>Total Due</u> (US\$)			

.....
[Name and Address of the Seller]

.....
[Signature]
[Name]

Adjustments to Operations Security

Annex F: Contracted Parameters and Values

Open Cycle Values		
Parameter	Units	Value
S_i	US\$/Immediate Re-start	
S_h	US\$/Hot Start	
S_w	US\$/Warm Start	
S_c	US\$/Cold Start	
CPI_i	N/A	
EC	kJ/kg	
EC_{nf}	US\$/kWh	

Combined Cycle Value		
Parameter	Units	Value
S_i	US\$/Immediate Re-start	
S_h	US\$/Hot Start	
S_w	US\$/Warm Start	
S_c	US\$/Cold Start	
CPI_i	N/A	
EC	kJ/kg	
EC_{nf}	US\$/kWh	

Annex G: TARIFF

Year	Capacity Charge (US\$ per MW per month)			Energy Charge Non-Fuel Component <i>EC_{nf,2014}</i> (\$/kWh)
	<i>CC_{ne}</i> Non-Escalable Component		<i>CC_{ei}</i> Escalable Component	
	Open Cycle Operation	Combined Cycle Operation		
1				
2				
3				
4				
5				
6				
7				
8				
9				
10				
11				
12				
13				
14				
15				
16				
17				
18				
19				

Energy and Water Utilities Regulatory Authority

20				
----	--	--	--	--

Schedule 6 - List of Independent Engineers

Parties may wish to pre-agree a shortlist of candidates for the role of Independent Engineer, in accordance with the Tanzanian laws governing institutions that are legally component and authorized to provide engineers to carry out arbiter issues.

Schedule 7 - Construction Reports

- **Clause 4.4 foresees that the Parties agree on a standard form report during the construction phase.**
- **Such a standard report may be tailored (taking into account the specifics of the Plant) and added to this schedule in order to allow the Purchaser to monitor the construction progress in a standardized form.**
- **If this is not required reference to this schedule in Clause 4.4.1.1 should be deleted.**

Schedule 8 - **Security Package**

To be agreed between the Parties.

Schedule 9 - Conditions Precedent

Part A - Seller Conditions Precedent

Part B - Purchaser Conditions Precedent

To be determined as appropriate on a case-by-case basis.

Possible conditions precedent include:

- a) **All or specific consents and permits having been obtained;**
- b) **All or specific insurance coverage having been obtained;**
- c) **The meeting of financial milestones or financial closure;**
- d) **Entering into force of additional agreements such as security and/or loan agreements and/or other project related documents;**
- e) **Obtaining of legal opinions confirming the authority and capacity of the parties/signatories to enter into the agreement;**
- f) **Provision of board resolutions related to the entering into the agreement (if necessary);**
- g) **Provision of constitutive documents of the Seller;**
- h) **If necessary, the adoption of any formal governmental acts that are required for the government entity involved to enter into the agreement;**
- i) **Entering into a fuel supply agreement and other similar agreements related to the fuel supply and ability of the Seller to provide fuel as needed.**

Clause 3 and Schedule 9 - have to be read in conjunction with clause 20.1 and the user of this document may elect to address any of the points mentioned above in either of these sections of the agreement depending on the desired remedy for not meeting any of these conditions and/or milestones.

Schedule 10 - Names of Initial Shareholders

Insert the names of the Initial Shareholders.

Schedule 11 - Termination Amounts

The following is an example of a mechanism for determining the transfer value of the project Seller, in line with many similar projects. It does not represent the only means of doing so - but the Parties shall agree on the alternative methodology and describe in detail herein below.

Part 1: Calculation of Transfer Values

1. Applicable Transfer Values

Column (1) of the table below sets forth the relevant event giving rise to the service of a Transfer Notice.

Column (2) sets forth the Party that has the right to serve a Transfer Notice pursuant to Clause 20.7 of this Agreement in respect of the event set forth opposite it in Column (1).

Column (3) sets forth the Transfer Value applicable to the Transfer Notice set forth opposite in Column (2).

(1) Termination Event	(2) Party serving Transfer Notice	(3) Transfer Value
Seller Event of Default	The Purchaser (pursuant to Clause Error! Reference source not found.)	The Purchaser will not be liable to pay the Transfer Value in this event but will be in accordance to Clause 9 (Lender's step in right)
Purchaser Event of Default	The Seller (pursuant to Clause [Error! Reference source not found.])	ATEI plus the Outstanding Project Debt.
Tanzania Political Event	Either Party	ATEI plus the Outstanding Project Debt.
Prolonged Natural Force Majeure	Either Party	<ul style="list-style-type: none"> • 5% of (Outstanding Project Debt minus Insurance Proceeds)
Termination at the end of the Term	the Purchaser	USD 1

* Note: For each of these payments, an amount equal to the Outstanding Project Debt will be subtracted and remitted to the Lenders in accordance with Clause 20.8.3 of this Agreement, with the balance being remitted to the Seller.

2. Calculation of Transfer Value

2.1 For the purposes of paragraph 1 of Part 1 of this Schedule 1 -:

- (a) "ATEI" or "**Adjusted Total Equity Invested**" shall mean an amount, in [USD], equal to the aggregate of all amounts representing equity remitted by the shareholders in the Seller for subscription of shares in the Seller prior to the date of the Transfer Notice, adjusted to effect the Agreed Rate of Return, from the date each amount representing equity was remitted by the shareholders in the Seller for subscription of shares in the Seller to the date of the Transfer Notice (and for this purpose any amounts remitted in a currency other than USD shall be converted into [USD] at the Reference Exchange Rate on the date such amount was remitted for subscription), adjusted by the amount of "**Net Cash Available**" (being the Seller's actual cash at bank, plus cash reserves (other than for contracted services), minus accounts payable, minus deferred tax liabilities, each as at the date of the Transfer Notice), minus an amount to reflect all returns of capital and all accumulated after tax distributions in each case made by the Seller to the shareholders in the Seller during the period from the date the relevant amounts representing equity were remitted to the shareholders in the Seller to the date of the Transfer Notice as per the formula;

$$ATEI = \sum_{n=1}^N E_n + \sum_{n=1}^N [ROE * E_n * (D_n/365)] + NCA - \sum_{s=1}^S DIV_s$$

Where:

- " E_n " represents an amount in USD equal to the Equity remitted by the shareholders for the nth round of equity contribution;
- " D_n " represents the total number of days from the date of E_n remitted by the shareholders to the Termination Date (both dates inclusive);
- " N " represents the total number of rounds of equity contribution up to the Termination Date;
- " ROE " represents the Agreed Rate of Return, as defined as an annual [16] % Return on Equity for the shareholders;
- " DIV_s " represents an amount in USD equal to the after-tax distributions made to the shareholders for the sth round of after-tax distributions; and
- " S " represents the total number of rounds of after-tax distribution up to the Termination Date.
- "**NCA**" represents Net Cash Available

- (b) "

2.2

3. Calculation of Transfer Liabilities and Transfer Benefits

3.1 In this Agreement:

- (a) **"Transfer Liabilities"** shall mean the sum of all the following liabilities (including contingent liabilities) to the extent existing or accruing as a result of or in connection with the ownership, construction, operation, maintenance or repair of the Plant by, or on behalf of, the Seller prior to the Asset Transfer Date, in each case, only to the extent not already accounted for in the Transfer Value:
 - (i) all those liabilities to be assumed by the Purchaser as a result of the assignment to it of all the contracts (including Project Documents) referred to in Clause 20.8.4 of this Agreement;
 - (ii) all those liabilities and claims made by third parties against the Seller under or pursuant to the contracts referred to in paragraph (i) above or arising by operation of law as referred to in paragraph (iii) below which transfer to, or are made against, the Purchaser as a result of the transfer of the Plant pursuant to this Agreement;
 - (iii) all those liabilities which accrue to the Purchaser as a matter of law (including liabilities accruing to the Purchaser in connection with the employment of the Seller's staff who transfer to the Purchaser as a result of the transfer of the Plant pursuant to this Agreement);
 - (iv) all liabilities (together, **"Contamination Liabilities"**) to remove all contaminants on the Site and to reinstate the Site to the extent required to comply with the applicable environmental Laws and standards (including any liabilities to third parties as a result of such contamination, whether or not claims have been made by third parties prior to the Asset Transfer Date); and
 - (v) all amounts due, or accrued, by the Seller to the Purchaser under, or in connection with, this Agreement;
- (b) **"Transfer Benefits"** shall mean the sum of all the following benefits (including contingent benefits) to the extent existing or accruing as a result of or in connection with the ownership, construction, operation, maintenance or repair of the Plant by, or on behalf of, the Seller prior to the Asset Transfer Date, in each case, only to the extent not already accounted for in the Transfer Value:
 - (i) where prior to the Asset Transfer Date, the Seller has received payment under any Insurance policies relating to the Plant, the balance of any such payment so received after application of any part of such proceeds in remedying the loss or damage in question or payment (whether voluntary or mandatory) of amounts outstanding under the Financing Documents;
 - (ii) claims outstanding and unpaid as at the Asset Transfer Date (including all claims under the Construction Contract) which the Seller is entitled

- to make but has not, as at the Asset Transfer Date, made, under any Insurance policies relating to the Plant;
 - (iii) the trade and book debts and receivables accruing due to the Seller prior to but unpaid at the Asset Transfer Date;
 - (iv) the benefit of liquidated claims under the assigned contracts (including warranties, guarantees, conditions, and indemnities under the Construction Contract) arising out of any events occurring or circumstances prior to the Asset Transfer Date and other outstanding claims under warranties, guarantees, conditions, indemnities, and otherwise;
 - (v) the benefit of any refund or repayment of taxes becoming payable after, but attributable to the construction, operation, maintenance, or repair of, or the sale of Net Energy Output and Ancillary Services from, the Plant, prior to the Asset Transfer Date; and
 - (vi) all amounts due by the Purchaser to the Seller under, or in connection with, this Agreement.
- 3.2 All calculations of the Transfer Liabilities and Transfer Benefits shall be made by the Seller and included in the draft Termination Statement pursuant to paragraph 1 of Part 2 of this Schedule 1 -.

Part 2: Termination Payments

1. Calculation of Termination Payments

- 1.1 The Seller shall prepare a draft Termination Statement in accordance with Clause 20.9.1 of this Agreement, setting out the following:
- (a) the Transfer Value;
 - (b) the Transfer Liabilities;
 - (c) the Transfer Benefits;
 - (d) an estimate of the amount in USD of interest on the Base Termination Amount from the date of the Transfer Notice to the Asset Transfer Date at the Default Rate.

2. Definitions

For the purpose of this Agreement:

"Base Termination Amount" means the amounts referred to in paragraphs 1.1(a) and (c) of Part 2 of this Schedule 1 -, minus the amount referred to in paragraph 1.1(b) of Part 2 of this Schedule 1 -.

Part 3: Post Completion Adjustments

1. Termination Statement Final and Binding

Except as provided in Paragraph 1.2 of Part 3 of this Schedule 1 - the Termination Statement as agreed or determined pursuant to Clause [] of this Agreement shall be final and binding on the Parties (and shall not be subject to appeal by way of arbitration or legal proceedings or otherwise).

2. Reopening the Termination Statement

- 2.1 If the Termination Statement is agreed (or deemed approved) pursuant to [Clause 20.9.3 or 20.9.4] of this Agreement, then the Purchaser may dispute the correctness of the Termination Statement by notice in writing to the Seller served within six (6) months of the date of the Termination Statement setting out in reasonable detail the errors or omissions made by the Seller in the Termination Statement. In relation to any Transfer Liabilities or Transfer Benefits which were contingent at the time the Termination Statement is so agreed or deemed approved, the Purchaser may only dispute the correctness of such amounts in the Termination Statement, on the basis of the information which was available to the Seller at the time the Termination Statement was prepared and not information which may have subsequently become available.

- 2.2 If the Transfer Value set out in the Termination Statement is FMV, then either Party may dispute the correctness of the Transfer Value by notice in writing to the other Party served within six (6) months of the date of the Termination Statement setting out in reasonable detail the errors or omissions made by the Valuer in making his valuation. In relation to any Transfer Liabilities or Transfer Benefits which were contingent at the time the Termination Statement was so agreed or deemed approved, the Purchaser may only dispute the correctness of such amounts in the Termination Statement, on the basis of the information which was available to the Seller at the time the Termination Statement was prepared and not information which may have subsequently become available.
- 2.3 If the Termination Statement is determined by the expert as provided in Clause 20.9.3 or 20.9.4 of this Agreement, then either Party may dispute the correctness of the Termination Statement by notice in writing to the other Party served within six (6) months of the date of the Termination Statement setting out in reasonable detail the errors or omissions made by the expert in the Termination Statement. In relation to any Transfer Liabilities or Transfer Benefits which were contingent at the time the Termination Statement is so agreed or deemed approved, a Party may only dispute the correctness of such amounts in the Termination Statement, on the basis of the information which was available to the expert at the time the Termination Statement was prepared and not information which may have subsequently become available.
- 2.4 the Purchaser shall, by notice to the Seller served within twenty four (24) months of the date of the Termination Statement, be entitled to require that adjustments be made to the Termination Statement to take into account any liabilities to remove contaminants on the Plant Site and reinstate the Plant Site to the extent required to comply with the Environmental Standards (including any liabilities to third parties as a result of such contamination, whether or not claims have been made by third parties prior to the Asset Transfer Date or afterwards) arising as a result of, or in connection with, the ownership, construction, operation, maintenance or repair of the Plant by, or on behalf of, the Seller prior to the Asset Transfer Date, to the extent such liabilities were not taken into account in the Termination Statement and were agreed to in the determination of the Termination Payment.
- 2.5 Any dispute between the Parties as to whether adjustments should be made to the Termination Statement pursuant to this paragraph 2 of Part 3 of this Schedule 1 -, or in relation to what such adjustments should be made to the Termination Statement pursuant to this paragraph 2 of Part 3 of this Schedule 1 -, shall, on the application of either Party, be referred to an expert in accordance with Clause 21.2.
- 2.6 The time limits for service of notices under the foregoing provisions of this paragraph 2 of Part 3 of this Schedule 1 - (inclusive) shall not apply in the event of fraud or intentional misrepresentation.
- 2.7 Notwithstanding anything to the contrary provided in this paragraph 2 of Part 3 of this Schedule 1 -, in no event shall the Termination Payment be less than the Project Debt.

Schedule 12 - Insurance

To be determined as appropriate on a case-by-case basis.

Typical types of insurance covering the Plant would include:

- 1. All Risks Marine Cargo insurance in an amount sufficient to cover the replacement cost of all plant and equipment shipped to and intended to become part of the Plant on a warehouse-to-warehouse basis and subject to deductibles of no more than [□];**
- 2. All Risks (Property Damage)/Operational insurance in an amount sufficient to cover the replacement cost of the Plant, including construction equipment and transit coverage for plant purchased within Tanzania and not subject to the insurance described in Paragraph 1 of this Schedule 12 - and subject to deductibles of no more than [□] for all other perils;**
- 3. Political Risk Insurance in an amount sufficient to cover political risks against the Project with reputable insurers or multilateral agencies acceptable to the Lenders;**
- 4. Employer Liability Insurance complying with the Laws of Tanzania or any other applicable jurisdiction and Employers' Liability Insurance with limits of at least [□] per occurrence and subject to deductibles of no more than [□];**
- 5. Comprehensive or Commercial General Liability insurance with bodily injury and property damage limits of at least [□] per occurrence and [□] in the aggregate and subject to deductibles of no more than [□]. Such insurance shall include specific coverage for contractual liability encompassing the indemnification provisions in Clause 14, broad form property damage liability, personal injury liability, explosion and collapse hazard coverage, liability for pollution (both gradual and sudden and accidental) products/completed operations liability, and, where applicable, protection and indemnity liability;**
- 6. Comprehensive Automobile Liability insurance with bodily injury and property damage combined single limits of at least [□] per occurrence covering vehicles owned, hired or non-owned and subject to deductibles of no more than [□];**
- 7. Excess Umbrella Liability Insurance with a single limit of at least [□] per occurrence in excess of the limits of insurance provided in Paragraphs 3, 4 and 5 of this Schedule 12 - and subject to deductibles of no more than [□]; and**
- 8. any additional coverages required by Law and or as the Seller deems necessary for the effective fulfilment of its obligations in this Agreement.**